



8 a.m. - 5 p.m. Sales Available  
International: 1-919-443-0207  
Toll Free: 1-888-551-3082



Visit Our Website  
[www.wakeindustrial.com](http://www.wakeindustrial.com)



Email Us  
[sales@wakeindustrial.com](mailto:sales@wakeindustrial.com)

*All Products from Wake Industrial, LLC, come with:*

### Sales and Repairs

We specialize in providing immediate product delivery when your system goes down. We have thousands of In-Stock automation products and offer a full range of repair options.

### Fast Shipping

We ship worldwide, offering any type of shipping method with all the major logistic companies such as FedEx, UPS, DHL, USPS, and a variety of freight carriers.

### Quality Guarantee

With standards like our 1 year warranty on ALL products, we can guarantee a better customer service experience than any other company within our industry.

### Damage Free Delivery



All of our products are cleaned, go through quality control and are shipped using a custom military grade foam to ensure your product arrives undamaged. We have the capability to ship both small 1lb products and large 200lb+ automation parts regardless of your location.

---

### Stay In Touch

Wake Industrial, LLC  
1620 Old Apex Road  
Cary, NC 27513

*Wake Industrial is not affiliated with nor an authorized distributor or representative of any manufacturers, brands or products listed.*

**Call:** 1-888-551-3082  
**International:** 1-919-443-0207  
**Fax:** 1-919-267-1705

**Email:** [sales@wakeindustrial.com](mailto:sales@wakeindustrial.com)  
**Website:** [www.wakeindustrial.com](http://www.wakeindustrial.com)



# DKS 1

## Intelligent Digital Servo Drive With Integrated Power Supply - Basic Unit

Project Planning Manual

DOK-DIAX02-DKS01\*\*\*\*\*-PRJ1-EN-P



**Titel** DKS 1 Intelligent Digital Servo Drive  
with Integrated Power Supply/Basic Unit

**Type of documentation:** Project Planning Manual

**Documenttype** DOK-DIAX02-DKS01\*\*\*\*\*-PRJ1-EN-E1,44

**Internal file reference**

- Mappe 13
- DKS01-PJ.pdf
- 209-0069-4355-00

**Reference** This electronic document is based on the hardcopy document with document  
desig.: 209-0069-4355-00 EN/05.94

**This documentation is used:** This document provides information for:

- Planning the electrical design
- Installing the servo drive in the control cabinet
- Installing the electrical cables on the servo drive

**Change procedures**

Designation of documentation up to present edition	Release- date	Coments
209-0069-4355-00 EN/05.94	May/94	First Edition
DOK-DIAX02-DKS01*****-PRJ1-EN-E1,44	Jan./97	Introduction of document type

**Copyright** © INDRAMAT GmbH, 1994  
Copying of this document, and giving it to others and the use or communication  
of the contents thereof, are forbidden without express authority. Offenders are  
liable to the payment of damages. All rights are reserved in the event of the  
grant of a patent or the registration of a utility model or design. (DIN 34-1)  
The electronic documentation (E-doc) may be copied as often as needed if  
such are to be used by the consumer for the purpose intended.

**Publisher** INDRAMAT GmbH • Bgm.-Dr.-Nebel-Straße 2 • D-97816 Lohr  
Telefon 0 93 52 / 40-0 • Tx 689421 • Fax 0 93 52 / 40-48 85  
Dept ENA (JH, FS)

**Validity** All rights reserved with respect to the content of this documentation and the  
availability of the products.

<b>Table of Contents</b>		Page
<b>1.</b>	<b>System Overview</b>	<b>5</b>
1.1.	Functional Performance Features .....	6
<b>2.</b>	<b>DKS 1 Servo Drive Units</b>	<b>7</b>
2.1.	Configured Servo Drive .....	7
2.2.	Servo Drive, Basic Unit .....	8
2.3.	Command Interface Cards .....	8
2.4.	Software Module .....	9
2.5.	Auxiliary Plug-In Cards .....	9
2.6.	Configuration Label .....	10
2.7.	Type Codes of the DKS 1 Servo Drive .....	11
2.8.	Configuration Table-Cards Used .....	12
<b>3.</b>	<b>Technical Data on the DKS Servo Drive</b>	<b>13</b>
<b>4.</b>	<b>Operating Conditions</b>	<b>15</b>
<b>5.</b>	<b>Information on the Use of Cooling Units in Enclosures</b>	<b>16</b>
<b>6.</b>	<b>Installing the DKS 1 Servo Drive</b>	<b>18</b>
<b>7.</b>	<b>Servo Drive Electrical Connections</b>	<b>20</b>
7.1.	General information .....	20
7.2.	Connecting the Basic Unit .....	21
7.3.	Grounding Requirements for the Electrical Power System .....	32
7.4.	Connection to the Electrical Power .....	34
7.4.1.	Direct Connection to Power System .....	35
7.4.2.	Connection to Electrical Power Via Transformer .....	36
7.5.	Interface Circuit for the DKS Servo Drive .....	39

<b>8. Accessories</b>	<b>42</b>
8.1. Connector Kits for DKS Basic Unit .....	42
8.2. Connector Kits for Configuration .....	43
8.3. Connectors for Individual Components .....	44
8.4. Selection of Optical Fiber Connections .....	46
<b>9. Condition as Shipped</b>	<b>47</b>
<b>10. Product Identification</b>	<b>48</b>
<b>11. Storage and Transport</b>	<b>50</b>
<b>12. Index</b>	<b>51</b>
<b>13. Supplementary Documentation</b>	<b>54</b>

# 1. System Overview

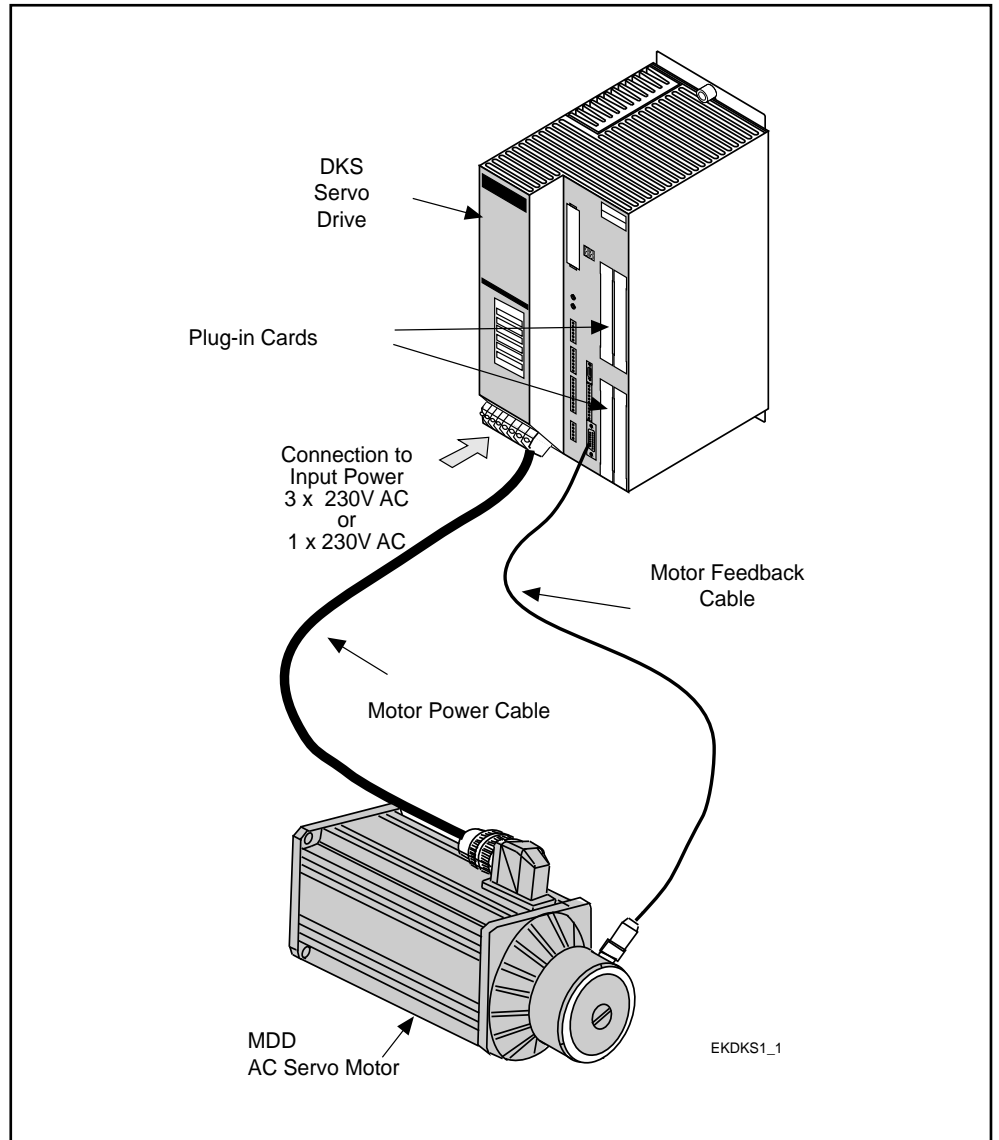

Figure 1.1: Drive system, components and terminology.

## 1.1. Functional Performance Features

- **Servo drive ready to connect to electrical power system**
  - The servo drive can be connected directly to a 230 V 3-phase power source.
  - The DKS 1.1-030-... can also be connected to a single-phase power source (1 x 230 V AC).
- **Power shutoff via integrated protection system**
  - A protection system is provided as an integral component of the DKS servo drive to shut off the supply of power to the drive.
- **Integral dynamic braking**
  - If trouble is encountered in the drive's electronic circuitry, the drive can be decelerated and stopped by means of an integral dynamic brake system.
- **Programmable error reaction**
  - In the event of power, drive, or system faults, the drive performs the programmed error reaction.
- **Inrush current limiting**
  - The inrush current does not need to be considered when selecting the fusing/circuit breaker for the input power.
  - Fusing/circuit breaker lifespan is extended.
- **Easy to service**
  - Signal cables are connected via screw terminals.
  - Extensive diagnostic capabilities and user-guided troubleshooting via alphanumeric display.
- **Motor holding brake**
  - Control and monitoring of the motor's holding brake is integrated inside the servo drive unit.
- **Flexibility for specific applications and operation modes**
  - The functions implemented on the drive can be matched to the given application by installing various plug-in modules on the servo drive.

## 2. DKS 1 Servo Drive Units

### 2.1. Configured Servo Drive

The DKS digital servo drive and the MDD digital AC servo motor combine to form a complete drive system.

A complete DKS servo drive consists of a basic unit which is customized for the given application by installing various cards in slots U1 to U5.

Indramat ships the DKS servo drive fully configured for the desired operation.

A configured servo drive consists of the following components:

- basic servo drive unit (section 2.2.)
- command interface card (section 2.3.)
- software module (section 2.4.)
- auxiliary plug-in card (section 2.5.)
- configuration label (section 2.6.)

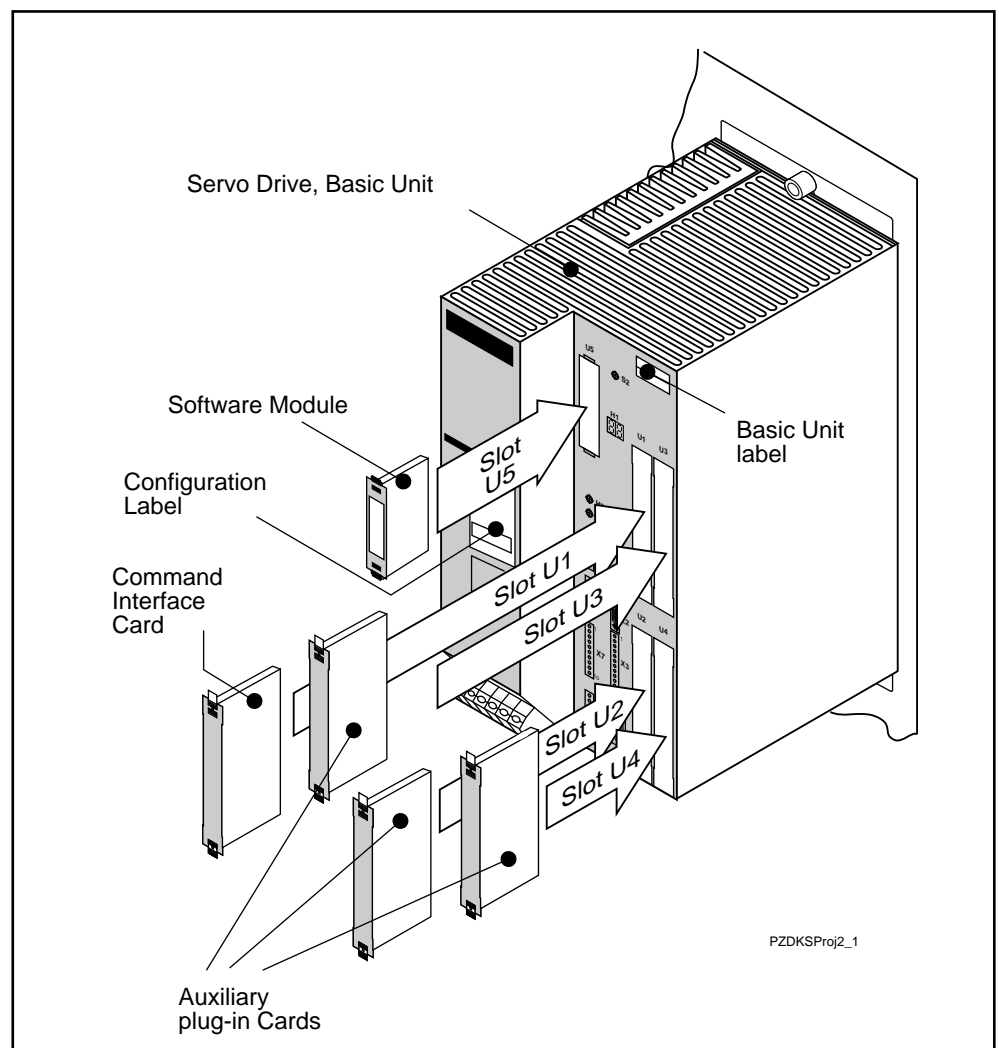

Figure 2.1: Components on the configured servo drive.



## 2.2. Servo Drive, Basic Unit

The slots for the plug-in cards are empty on the basic unit.

## 2.3. Command Interface Cards

The term „command interface card“ is a general term for various plug-in cards.

These cards provide the connection between the drive and the control.

The following command interface cards are available:

- SERCOS interface types: DSS 1.1, DSS 1.3
- ANALOG interface with incremental encoder emulator type: DAE 1.1
- ANALOG interface with absolute encoder emulator type: DAA 1.1
- Positioning card type: DLC 1.1

<i>SERCOS Interface</i>	Type: DSS 1.1, DSS 1.3 The „SERCOS interface DSS“ card allows the digital drives to be operated with SERCOS interface-compatible controllers via fiber optic cables. The interface also has inputs for evaluating reference switches, position limit switches and sensors.
<i>ANALOG Interface with Incremental Encoder Emulator</i>	Type: DAE 1.1 The „ANALOG interface with incremental encoder emulator“ card permits the intelligent digital AC servo drive to be operated with conventional controllers via an analog interface. It also contains control inputs and signal outputs for communication with an attached controller, and it outputs incremental encoder signals to be used as an actual position value.
<i>ANALOG Interface with Absolute-Value Encoder Emulator</i>	Type: DAA 1.1 The „ANALOG interface with absolute encoder emulator“ card permits the intelligent digital AC servo drive to be operated with conventional controllers via an analog interface. It also contains control inputs and signal outputs for communication with an attached controller, and it outputs actual absolute position values in accordance with the SSI Standard (Synchronous Serial Interface).
<i>Single-Axis Positioning Card</i>	Type: DLC 1.1 The „Single-Axis Positioning Card“ upgrades the servo drive to perform stand-alone single-axis position control. This card can be programmed with up to 3000 program blocks. Each program block defines a sequence of movements, a specific condition of the inputs to be monitored, or the outputs to be set.

## 2.4. Software Module

Type: DSM 2.1

Various software cards are required for their respective functions.

The software module contains the operating software and the drive parameters.

The required software module will depend on which drive configuration is selected.

The software module ensures that when hardware is replaced, the previously entered parameters can be carried over to the new hardware by simply plugging in the old software module.

## 2.5. Auxiliary Plug-In Cards

The following cards are generally referred to as „auxiliary plug-in cards.“

### *I/O Interface*

Types: DEA 4.1, DEA 5.1, DEA 6.1

These plug-in cards each have fifteen inputs and sixteen outputs which the drive can use to exchange binary signals with a programmable controller. The three types differ with regard to the internal address which is set on the card.

### *Incremental Position Interface*

Type: DEF 1.1, DEF 2.1

These „incremental position interface“ auxiliary plug-in cards are used to receive square wave signals so that data from an external measuring system located directly on the moving machine element can be input to the servo drive. The cards differ according to which internal address is set on the card.

### *High-Resolution Position Interface*

Type: DLF 1.1

The „high-resolution position interface“ auxiliary card is used to transfer sine wave signals so that data from a measuring system located directly on the moving machine element can be input to the servo drive.



**The technical data and connection diagrams for the plug-in cards are found in the documentation on „Plug-In Cards for the Intelligent Digital Servo Drives,“ doc. no.: 209-0069-4356**

## 2.6. Configuration Label

The configuration label contains the type code for:

- the configured servo drive
- the basic unit
- the software module in slot U5
- the plug-in cards in slots U1 to U4

These type codes can be used to determine which components must be located in which slots.

In the event of trouble, the information on the configuration label can be used to obtain a corresponding unit or to configure a basic unit. A replacement unit results when a basic unit is configured with the cards identified on the configuration label.



**The configuration label indicates which cards are installed on the servo drive. Before putting the servo drive unit into service, check to be sure that the actual configuration matches the configuration label.**

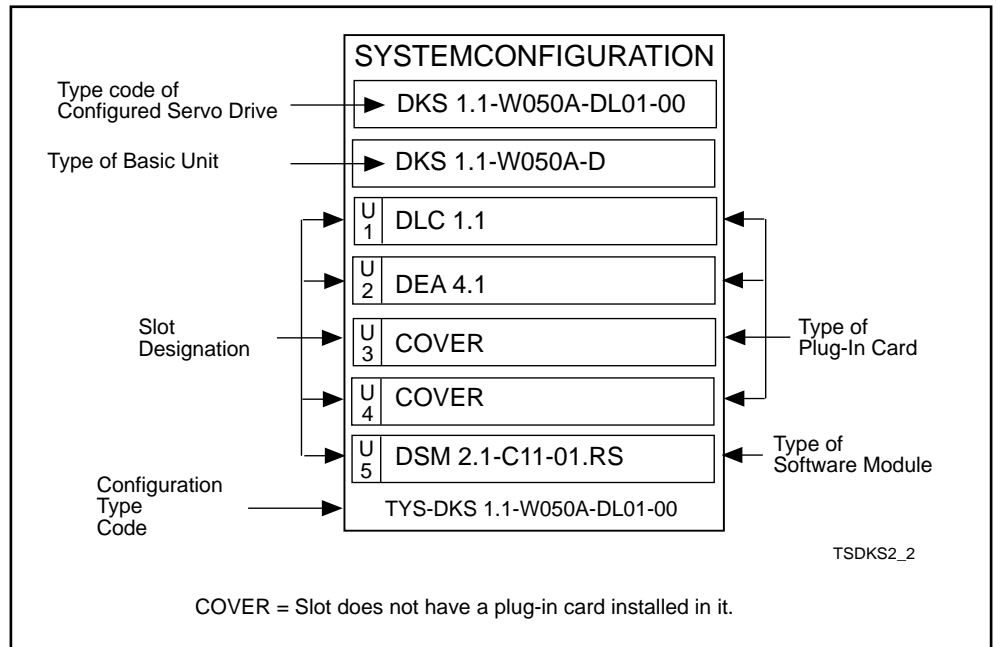

Figure 2.2: Example of a configuration label.

## 2.7. Type Codes of the DKS 1 Servo Drive

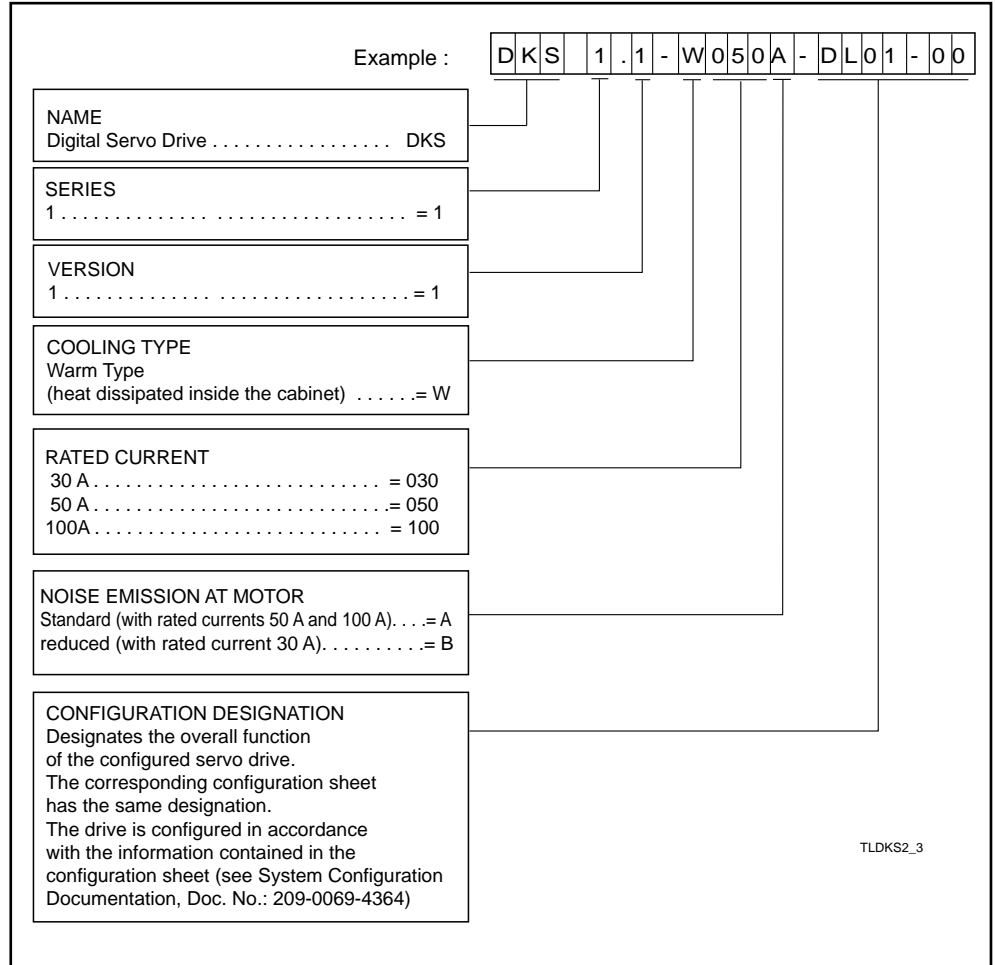

Figure 2.3: Type Codes of the DKS 1.

Each configuration also has a configuration sheet containing the identical designation.

The configuration sheet provides the following information:

- broad summary of installed functions
- definition of the drive unit consisting of the configured servo drive and the motor
- names of the components used on the configured servo drive in the parts list

## 2.8. Configuration Table-Cards Used

Configuration	Basic Unit	Slot U1	Slot U2	Slot U3	Slot U4	Slot U5
DA01-00	DDS 2.1-....-D	DAE 1.1	COVER	COVER	COVER	DSM 2.1-E11-01.RS
DA02-00	DDS 2.1-....-D	DAA 1.1	COVER	COVER	COVER	DSM 2.1-A11-01.RS
DA03-00	DDS 2.1-....-D	DAE 1.1	DEA 4.1	COVER	COVER	DSM 2.1-E11-01.RS
DL01-00	DDS 2.1-....-D	DLC 1.1	DEA 4.1	COVER	COVER	DSM 2.1-C11-01.RS
DL02-00	DDS 2.1-....-D	DLC 1.1	DEA 4.1	DEA 5.1	COVER	DSM 2.1-C11-01.RS
DL03-00	DDS 2.1-....-D	DLC 1.1	DEA 4.1	DEA 5.1	DEA 6.1	DSM 2.1-C11-01.RS
DL04-00	DDS 2.1-....-D	DLC 1.1	DEA 4.1	DEF 1.1	COVER	DSM 2.1-C11-01.RS
DL05-00	DDS 2.1-....-D	DLC 1.1	DEA 4.1	DEA 5.1	DEF 1.1	DSM 2.1-C11-01.RS
DS01-01	DDS 2.1-....-D	DSS 1.3	COVER	COVER	COVER	DSM 2.1-S11-01.RS
DS03-01	DDS 2.1-....-D	DSS 1.3	DEF 1.1	COVER	COVER	DSM 2.1-S11-01.RS
DS04-01	DDS 2.1-....-D	DSS 1.3	DLF 1.1	COVER	COVER	DSM 2.1-S11-01.RS
DS05-00	DDS 2.1-....-D	DSS 1.1	DEF 1.1	DEF 2.1	COVER	DSM 2.1-SZU-01.RS
RA01-00	DDS 2.1-....-R	DAE 1.1	COVER	COVER	COVER	DSM 2.1-E11-01.RS
RA02-00	DDS 2.1-....-R	DAA 1.1	COVER	COVER	COVER	DSM 2.1-A11-01.RS
RL01-00	DDS 2.1-....-R	DLC 1.1	DEA 4.1	COVER	COVER	DSM 2.1-C11-01.RS
RL02-00	DDS 2.1-....-R	DLC 1.1	DEA 4.1	DEA 5.1	COVER	DSM 2.1-C11-01.RS
RL03-00	DDS 2.1-....-R	DLC 1.1	DEA 4.1	DEA 5.1	DEA 6.1	DSM 2.1-C11-01.RS
RL04-00	DDS 2.1-....-R	DLC 1.1	DEA 4.1	DEF 1.1	COVER	DSM 2.1-C11-01.RS
RL05-00	DDS 2.1-....-R	DLC 1.1	DEA 4.1	DEA 5.1	DEF 1.1	DSM 2.1-C11-01.RS
RS01-01	DDS 2.1-....-R	DSS 1.3	COVER	COVER	COVER	DSM 2.1-S11-01.RS
RS03-01	DDS 2.1-....-R	DSS 1.3	DEF 1.1	COVER	COVER	DSM 2.1-S11-01.RS
RS04-01	DDS 2.1-....-R	DSS 1.3	DLF 1.1	COVER	COVER	DSM 2.1-S11-01.RS

Figure 2.4: Table showing various configurations of the basic unit.

### 3. Technical Data on the DKS Servo Drive

Designation	Symbol	Unit	DKS1.1-W030B-D		DKS1.1-W050A-D		DKS1.1-W100A-D	
			-R	Resolver	-R	Resolver	-R	Resolver
Encoder Type			DSF	Resolver	DSF	Resolver	DSF	Resolver
Motor Type to be Used			MDD		MDD		MDD	
Rated Current	I (typ)	(A)	30		50		100	
Peak Current	I (peek)	(A)	30		50		100	
Continuous Current	I (cont)	(A)	15 [10]		25		50	
PWM Frequency	f (PWM)	(kHz)	18		4			
Connection			Single-Phase or 3-Phase		3-Phase			
Input Voltage	U (ACN)	(V)	1x 230 (±10%) or 3x 230 (±10%)		3x 230 (±10%)			
Frequency	f (N)	(Hz)	50 . . . 60					
Rated Power Requirement		(kVA)	Depends on motor/servo drive combination, see list of recommended combinations					
Power Requirement (at max. drive loading)		(kVA)	4,5 [3,5]		9,5		11	
Internal Bus DC Voltage	U (DC)	(V)	300					
Bleeder Continuous Power (Continuous Regenerated Power)	P (BD)	(kW)	0,3		0,35		0,5	
Bleeder Peak Power (Peak Regenerated Power)	P (BM)	(kW)	5		9,4		18	
Power loss at max. device loading excluding power loss at bleeder	P (V)	(W)	230 [195]		305		480	
Operating Conditions								
Permissible ambient temperature for rated specifications	T (um)	(°C)	+5 to +45					
Max. ambient temperature with derated specifications	T (um)	(°C)	+55					
Storage and Shipping Temperature	T (L)	(°C)	-30 to +85					
Max. Elevation without derating			max. 1000 m above sea level					
Max. Humidity according to humidity classification			F per DIN 40 040					
Insulation Class			C per DIN 570 110					
Protection Class			IP 10 per DIN 40 050					
Weight	m	(kg)	Approx. 11					

[ . . . ] Values apply to DKS 1.1-W030B- with single-phase power connection

TDDKS3\_1

Figure 3.1: Technical data on the DKS servo drive.

**Power Loss** Power losses occur in the DKS in the electronic and power sections as well as in the bleeder.

**Losses in the electronic and power sections** Adding together the maximum power losses for the drive types when determining power losses in the control cabinet does not take into account the actual continuous load on the drive.

When averaged over time, the maximum current flowing to the drive is the continuous stall current  $I_{dN}$  of the motor (see motor documentation).

The actual resulting power loss depends on the continuous stall current  $I_{dN}$  of the motor which is connected. The value for the continuous stall current  $I_{dN}$  may be found in the documentation for the motor.

**Example** Drive:  
Motor Stall:  
Stall current  $I_{dN}$  of the motor:

Power loss determined from Figure 3.2:

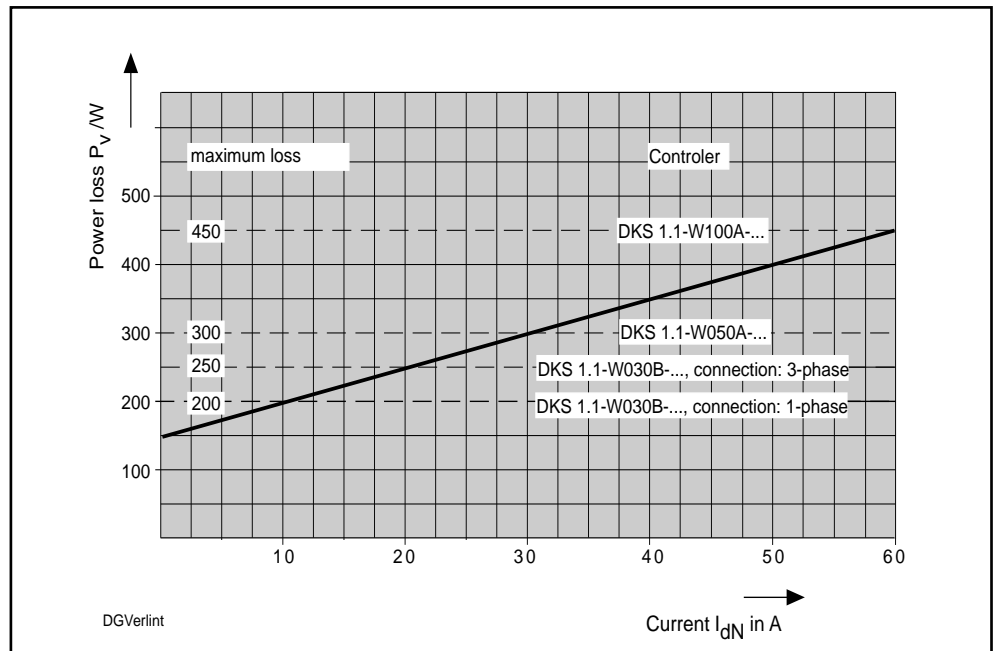

Figure 3.2: Determination of the power loss to the enclosure.

**Bleeder Losses** The bleeder losses depend on the rotational drive energy, the potential energy of unbalanced masses, and the machine cycle.

**Equation**

$$P_{RD} = \frac{W_{rotg} + W_{potg}}{t_z}$$

**$P_{RD}$**  = continuous regenerated power or bleeder loss in kW  
 **$t_z$**  = cycle time in seconds  
 **$W_{potg}$**  = total of potential energies in kW  
 **$W_{rotg}$**  = total of rotational energies in kW

## 4. Operating Conditions

### Ambient Temperature

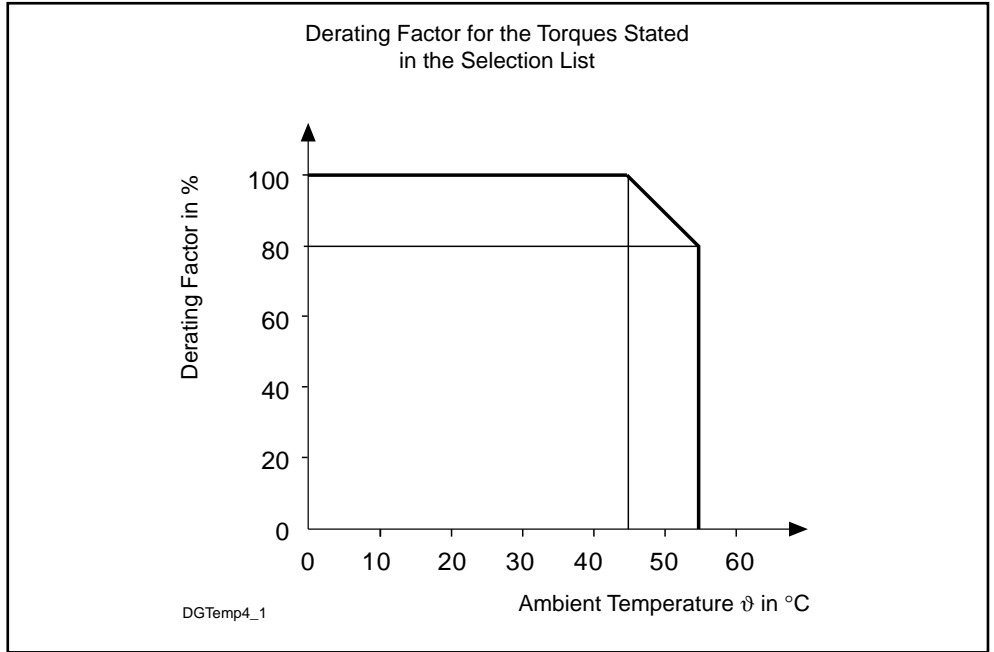

Figure 4.1: Derating performance data as a function of ambient temperature.

### Elevation above 1000 meters

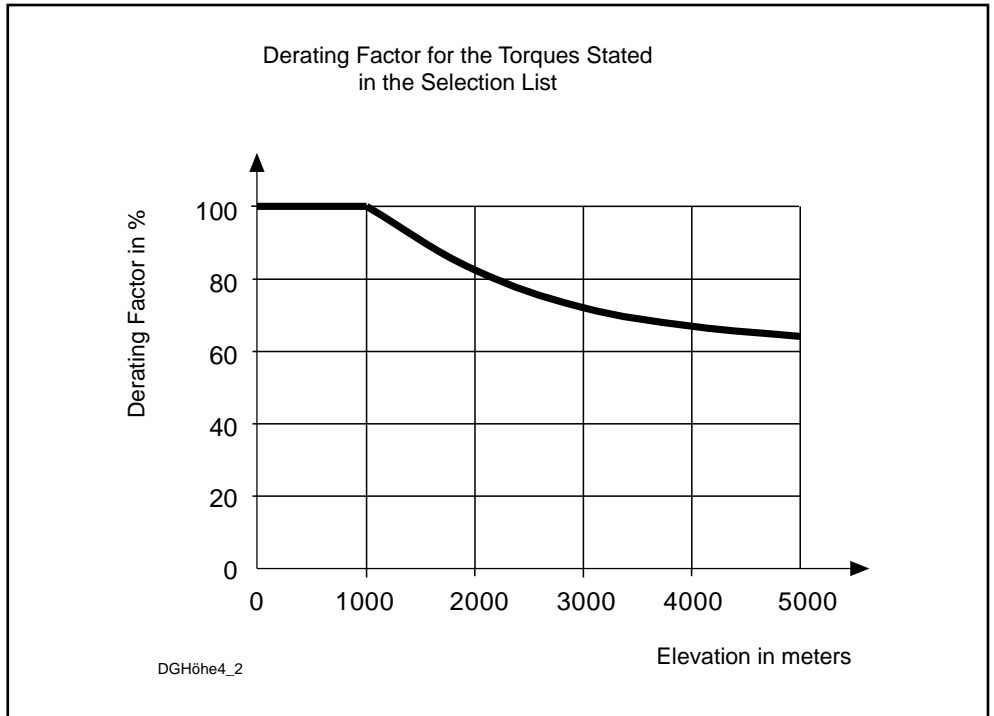

Figure 4.2: Derating performance data as a function of elevation.

### Maximum Humidity

The maximum ambient air humidity is humidity class F per DIN 40 040.

In other words, the device may be operated under humid conditions, as for example in factories in cold, moderate, and dry climates. The mean relative humidity must not exceed 70% in the most humid month of the year! No water must ever be allowed to condense on the equipment!



## 5. Information on the Use of Cooling Units in Enclosures

In order to maintain proper environmental conditions in enclosures, it may be necessary to use a cooling unit to cool the air inside the enclosure.

Improperly used cooling units represent a threat to installed drives due to condensation!

*Condensation Hazards* Warm humid air enters the enclosure and moisture condenses on the drives when it cools!

*Condensate Hazards* Condensate, the water resulting from condensation, which is always present in cooling units, can drip down into the installed drives or be sprayed in with the circulating cooling air if the unit is improperly positioned in the enclosure.

### *Proper Use of Cooling Units*

*Avoiding Condensation*

- Use only tightly sealed control cabinets with cooling units, so that no warm humid air can enter from the outside and cause condensation!
- If enclosures are operated with the doors open (during setup, service, etc.) care must be taken to ensure that after the doors are closed the drives can never be cooler than the air in the cabinet, since this could cause condensation. Therefore, the cooling unit must continue to be operated even when the system is shut off until the temperature of the air in the enclosure and that of the installed equipment are at the same level.
- Set cooling units having a fixed temperature setting to 40°C and no lower!
- Cooling units having variable temperature controls should be adjusted in such a way that the temperature of the air inside the enclosure never is less than the outside air temperature. Set the temperature limit to 40°C!

*Avoid Dripping or Spraying of Condensate* Always install the cooling unit in such a position that any condensate that forms cannot drop down onto the drives installed in the enclosure. Cooling units installed on the top of the enclosure require a special enclosure design (see Figure 5.1)!

The enclosure must be designed in such a way that any condensate which collects after OFF periods cannot be sprayed by the cooling unit blower onto the drives (see Figure 5.2.)!

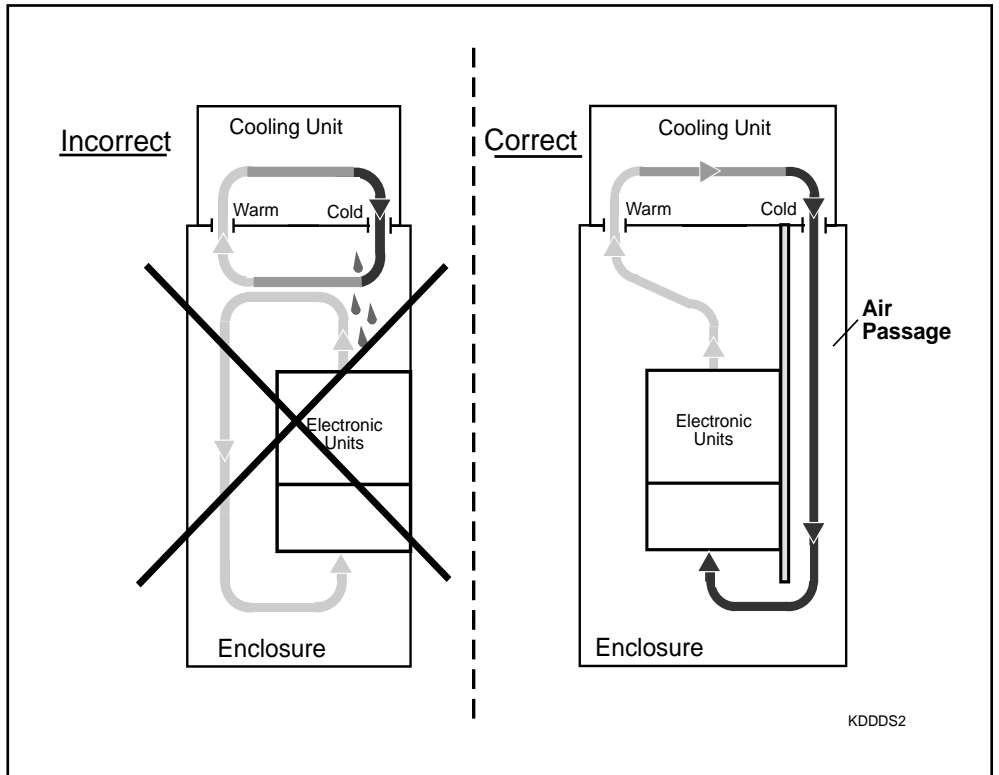

Figure 5.1: Location of cooling unit on the top of the control cabinet.

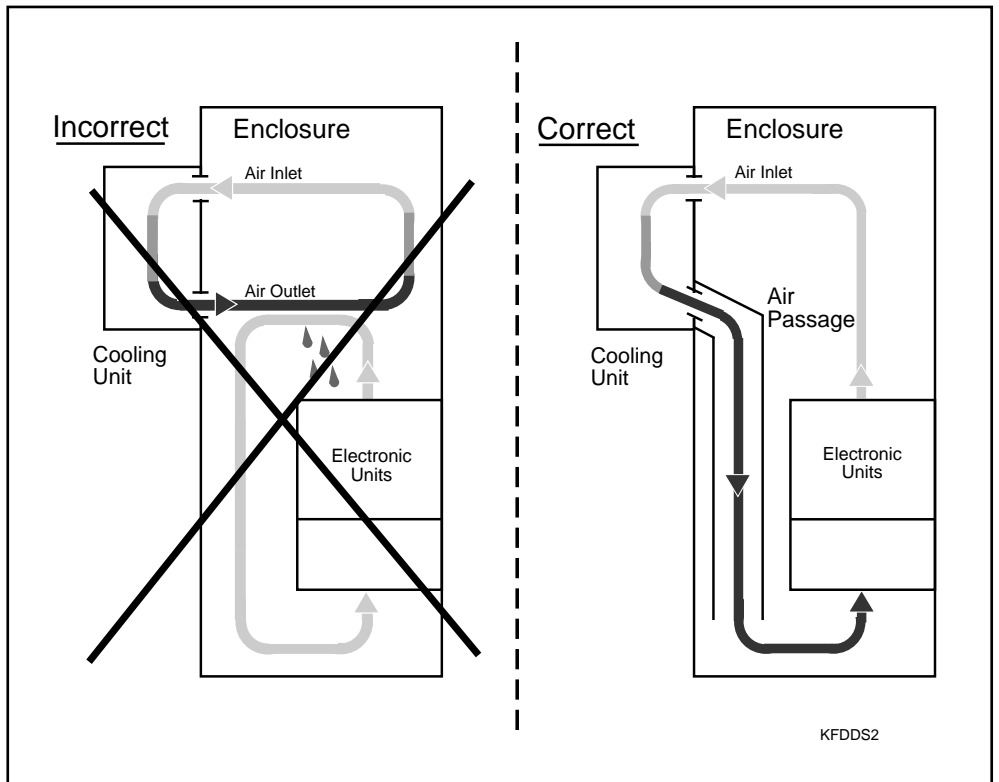

Figure 5.2: Cooling unit located on the front of the control cabinet.



- Care must be taken to ensure that no condensate drips down from the cooling unit into the drives installed in the control cabinet!
- Be certain that the temperature setting on the cooling units is correct!

## 6. Installing the DKS 1 Servo Drive

*Installation Requirements* The servo drive is intended for installation in a control cabinet or closed housing and in accordance with protection class IP 10 per DIN 40 050.

This means that the device is protected against the penetration of solid, foreign objects greater than 50 mm in diameter.

The device is not protected against:

- water entry, or,
- intentional penetration.

## 6. Installing the DKS 1 Servo Drive

### Dimensional drawing of DKS 1 Servo Drive

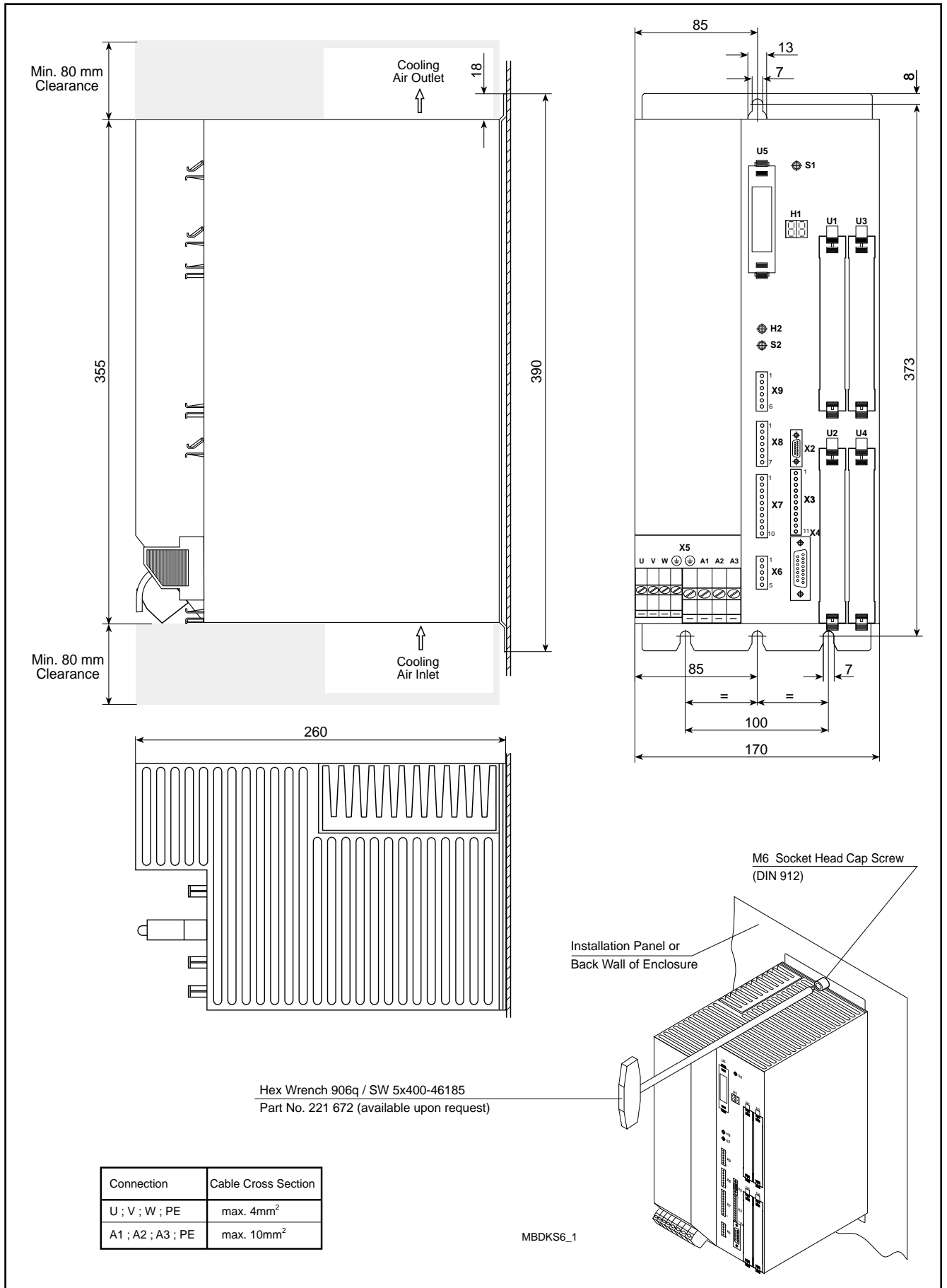

Figure 6.1: Outline drawing showing dimensions of DKS servo drive.

## 7. Servo Drive Electrical Connections

### 7.1. General information

- Route the signal cables separate from power cables to avoid interference. Connect all signal cables using push-in terminals or D-subminiature connectors so that equipment can be quickly replaced.
- Transmit analog signals through shielded cables and connect shielding only to the drive module.
- Power and motor cables must not be combined with or come into contact with the low voltages 15 V DC and +24 V DC
- If the electrical equipment on the machine is to be subjected to a high-voltage test or a separate-source voltage-withstand test, then all connections on the devices must be disconnected or pulled so that the electronic components in the devices are not damaged (permitted per VDE 0113). The INDRAMAT drive components are subjected to high-voltage testing per VDE 0160 during component testing.
- Electrostatic charges can be harmful to electronic components. Any objects which can come into contact with components and circuit boards must be discharged by grounding:
  - the human body by touching a conductive grounded object,
  - the soldering iron when soldering work is being performed,
  - parts and tools must be placed on a conductive surface.

Any components which might be damaged by electrostatic charges, for example plug-in cards, must be stored or shipped in electrically conductive packaging only.
- In order to meet interface suppression standards at machine or system connection points, especially in areas zoned for residences and light industry, the motor power cable must be routed so that it is shielded or a shielded motor cable must be used. Also, one of the interference suppression filters recommended by INDRAMAT must be properly installed in the power input line to the machine or system. If these precautions are taken, class B standards (spark suppression class N) per EN 5501/3.91 and Table I per EN 55014/1987 are met at the machine.

## 7.2. Connecting the Basic Unit

Basic Layout

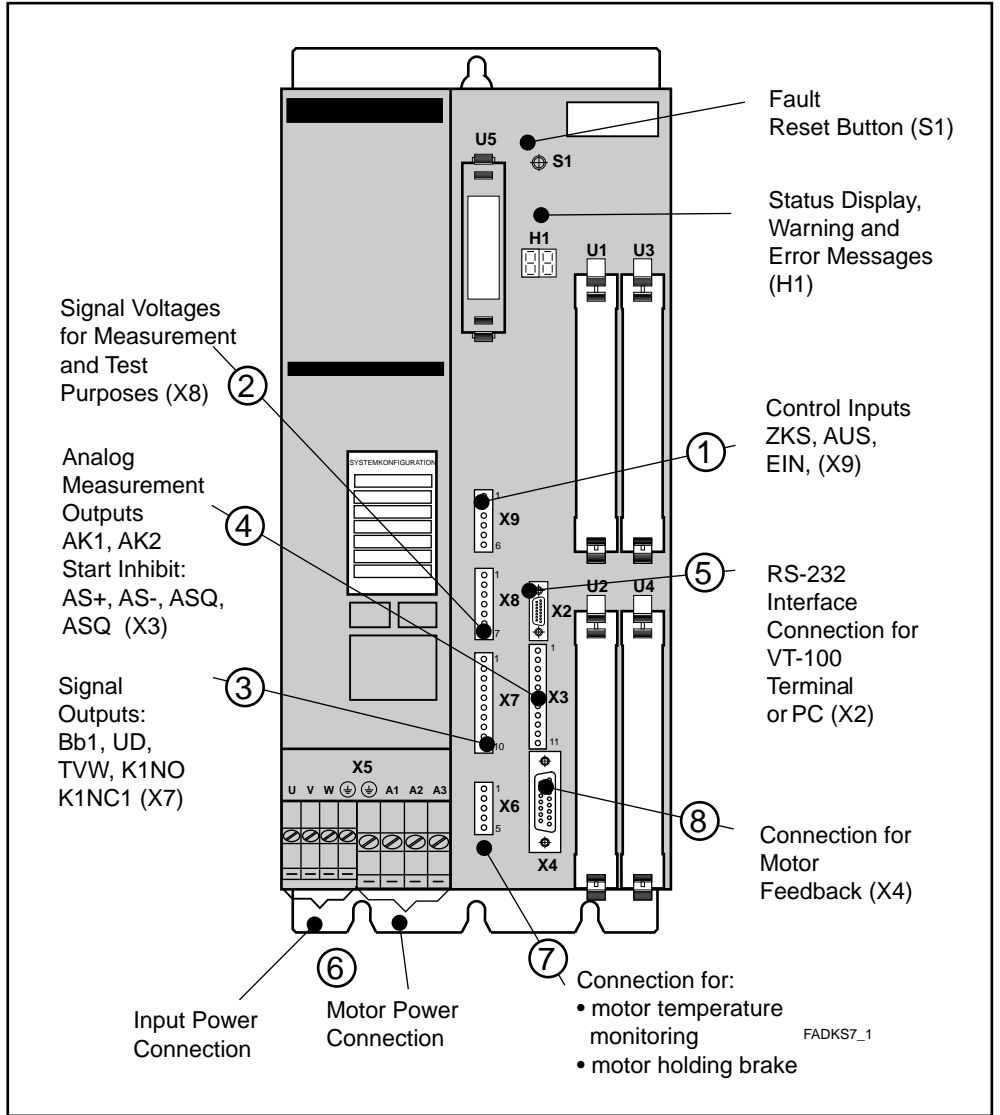

Figure 7.1: Front view with connection labels and explanations.

See the following pages for explanation of items ① - ⑨.

Interface Definition Push-in terminal blocks X9, X8, X7, X6, X3, X2

① Terminal Block X9,  
DC Bus  
Short-circuiting,  
Main Contactor

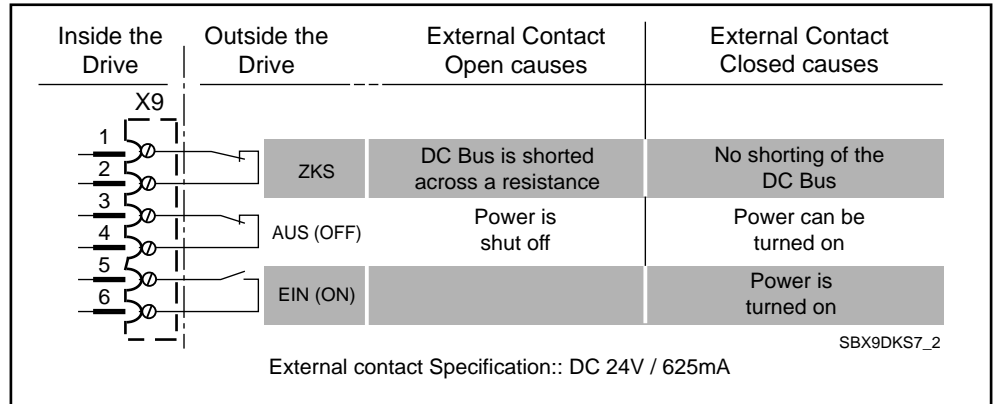

Figure 7.2: Operating states of the inputs on terminal block X9

**ZKS Input** The main contactor on the DKS cannot be turned on unless the ZKS input is closed.

As an additional safety feature when trouble occurs in the drive’s electronic system, the drive can be braked to a stop by opening the ZKS input. This causes the bus voltage to be shorted internally in the DKS.

**AUS (Off) Input** Only when the AUS (off) input is closed can the main contactor in the DKS be activated.

If the AUS input is opened, for example in the event of E-Stop (emergency stop), then the main contactor on the DKS is turned off immediately. However, the internal bus is not shorted.

**EIN (On) Input** If the ZKS and AUS (off) inputs are closed and the device is ready, closing the EIN (on) input will perform a soft start for the power section in the DKS.

The main contactor in the DKS is then automatically activated. The main contactor then goes to a self-holding state. The activation pulse must be present for approximately five seconds.

② Terminal Block X8, Signal Voltages

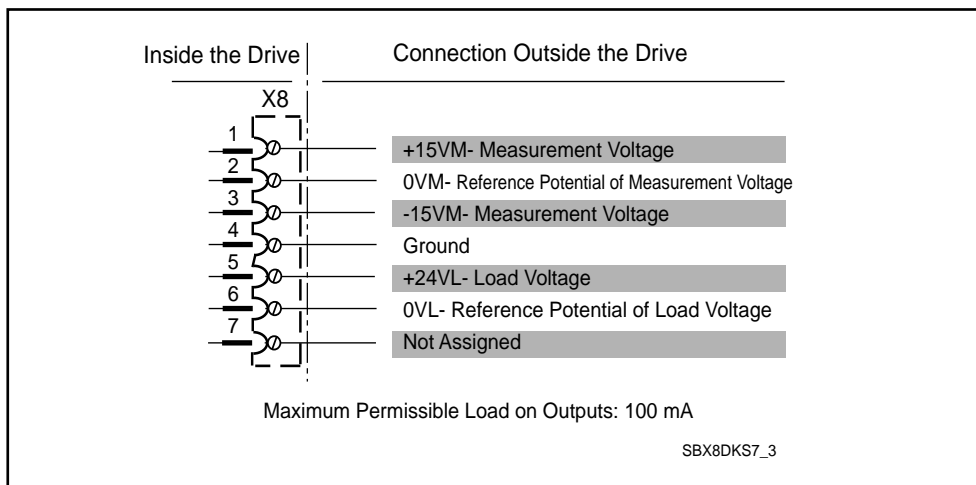

Figure 7.3: Signal voltages at push-in terminal block X8.

Signal Voltages for Measurement and Test Purposes

15 V DC and +24 V DC can be drawn from terminal block X8. These terminals are used for measurement and test purposes. If these voltages are used outside the DKS, care must be taken to ensure that no interference voltages are injected into the device (use short shielded leads).



**The voltage outputs are short-circuit proof. The maximum load of 100 mA must not be exceeded if the drive is to function properly.**



③ Terminal Block X7,  
Signal Outputs

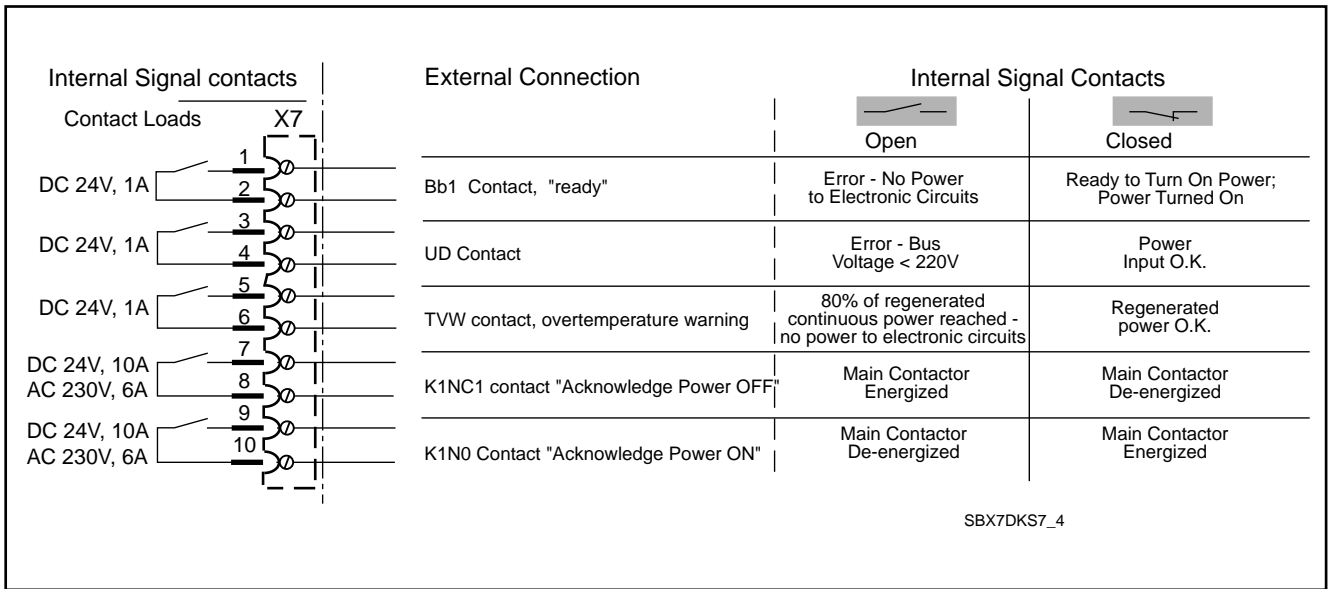

Figure 7.4: Signal outputs on terminal block X7.



**Contacts: Bb1, UD, TVW**

**Connection values max. 24 V, 1 A short-term and continuous.**

**A contactor coil must not be connected directly via the relay contacts. High short-term currents on the relay contacts can cause overloading during frequent switching and therefore could cause failure.**

**Varistors must not be used to provide a protective circuit. Over the course of their life, these devices consume increasingly higher currents, which can lead to premature component failure.**

*Bb1 Contact* The Bb1 contact signals that the drive system is ready for the power to be turned on.

The interlocks in the device do not permit the main contactor in the DKS to be turned on until this contact is closed. In the event of an error, the main contactor is deactivated and the Bb1 contact is opened. If this occurs, the drive may not be decelerated in a controlled manner.

The Bb1 contact closes if voltage is applied to X5/U1, X5/V1 and X5/W1 and no error is present.

The Bb1 contact opens in event of the following errors:

- overtemperature
- drive overcurrent
- failure of the  $\pm 15$  VM/ +24 VL signal voltage
- heatsink temperature in the DKS is too high
- overcurrent in the power section of the DKS
- overvoltage
- bleeder overload

*UD Contact* The UD contact acknowledges that the DKS has been properly supplied with power.

It opens when the following faults are encountered:

- DC Bus voltage < 200 V

Use:

- required condition for feed enable
- diagnostics

*TVW Contact* The TVW (temperature advance warning) contact opens when the continuous feedback power is > 80% of the continuous bleeder power. If the bleeder load continues to increase until a thermal overload occurs, then the supply of power in the DKS is interrupted.

The TVW contact can be evaluated in the controller to limit regenerated power before a power shutoff occurs.

*K1NO-Contact*  
*Acknowledge Power*  
*On* The K1NO output can be scanned to determine whether the main contactor is energized. The presence of a closed K1NO contact can be used as a condition for enabling closed-loop control on the drive.

*K1NC1- Contact*  
*Acknowledge Power*  
*Off* The K1NC1 outputs can be scanned to determine whether the main contactor is de-energized. These outputs can be used as a condition for enabling a door interlock.

④ Terminal Block X3,  
Analog Inputs and  
Outputs

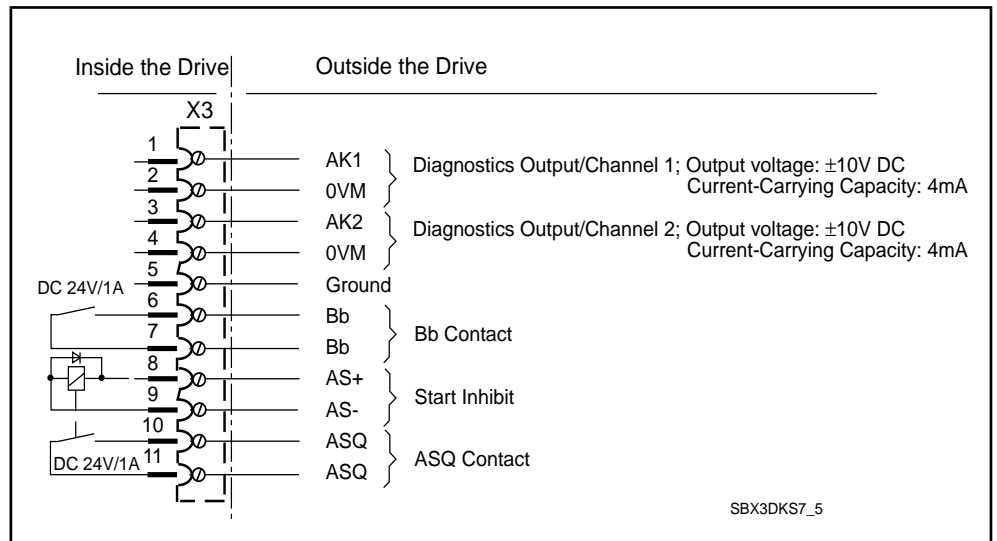

Figure 7.5: Analog inputs and outputs on terminal block X3

*Analog Diagnostics  
Outputs: AK1 / AK2*

The analog diagnostics outputs are measuring points which can be used to output values generated within the drive for test purposes (for example during setup). Additional information on the analog diagnostics outputs maybe found in the Applications Manual.

Current-Carrying Capacity: 4 mA

Output Voltage: 10 V DC

*Ready State Contact:  
Bb*

If the ready state contact „Bb“ closes, then the servo drive is ready for high voltage. The „Bb“ contact closes when the control voltage is applied and all monitoring functions report a proper condition.

The drives internal interlocks in the unit do not permit the main contactor in the DKS to be energized until this contact is closed. In the event of an error, the Bb contact opens and the main contactor is turned off. When the Bb contact is open, the drive cannot be expected to brake in a controlled manner. The Bb contact can therefore be used to activate dynamic braking.

Contact rating: 24 V DC, 1 A (short-term and continuous)



**A contactor coil must not be connected directly via the Bb relay contacts. High short-term currents on the relay contacts can cause overloading during frequent switching and, therefore, could cause failure.**

**Varistors must not be used to provide a protective circuit. Over the course of their lives, these devices consume increasingly higher currents. This can lead to premature component failure.**

*Start Inhibit: AS+, AS-, ASQ, ASQ*

The start inhibit provides protection to ensure that the motor will not start unexpectedly when a fault occurs.

**The start inhibit is not used to stop moving axes.**

AS+, AS-: Control input for relay coil  
Voltage: 20 V to 30 V DC  
Power: 1.5 W

ASQ, ASQ; Potential-free contact, which acknowledges activation of the start inhibit to an external controller.  
Contact load: 24 V DC ,1A (short-term and continuous)

To activate the start inhibit, apply a voltage of +20 V to 30 V DC to input terminals AS+, AS-. Operation of the internal start inhibit relay is acknowledged to the external controller by the closing of the potential-free acknowledgement contact (output ASQ-ASQ).

⑤ Terminal X2, RS-232 Interface

When setting up drive controls with an analog interface or a positioning card, a VT-100 terminal or a PC having a VT-100 terminal emulation program can be connected to this interface.

Connection X2

A ready-made cable is available to connect a PC (cable lengths equal 2, 5, 10, and 15 meters) .

This cable is required to set up the servo drive with an analog interface (DAE, DAA) or a positioning card (DLC).

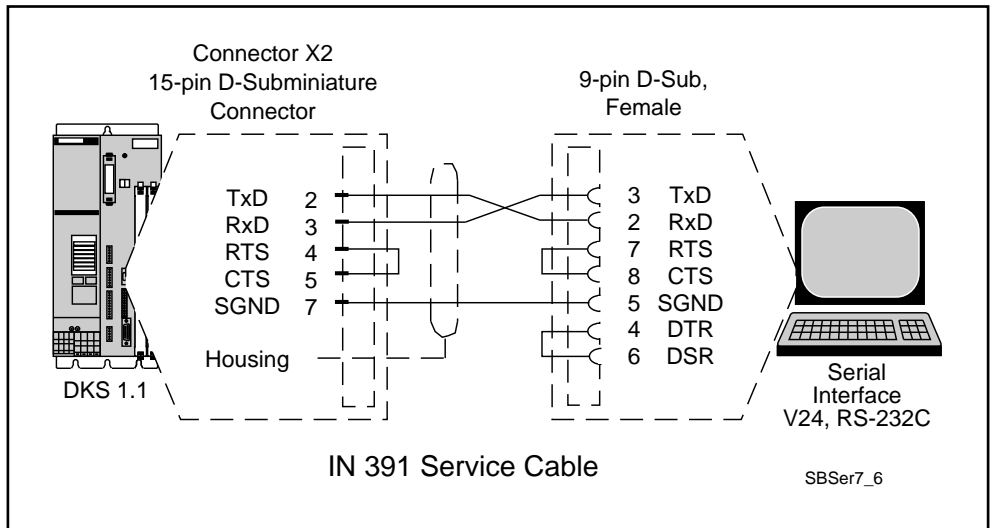

Figure 7.6: Connecting the DKS to a PC at terminal X2.

⑥ Terminal X5  
Motor Power and Input  
Power Connection

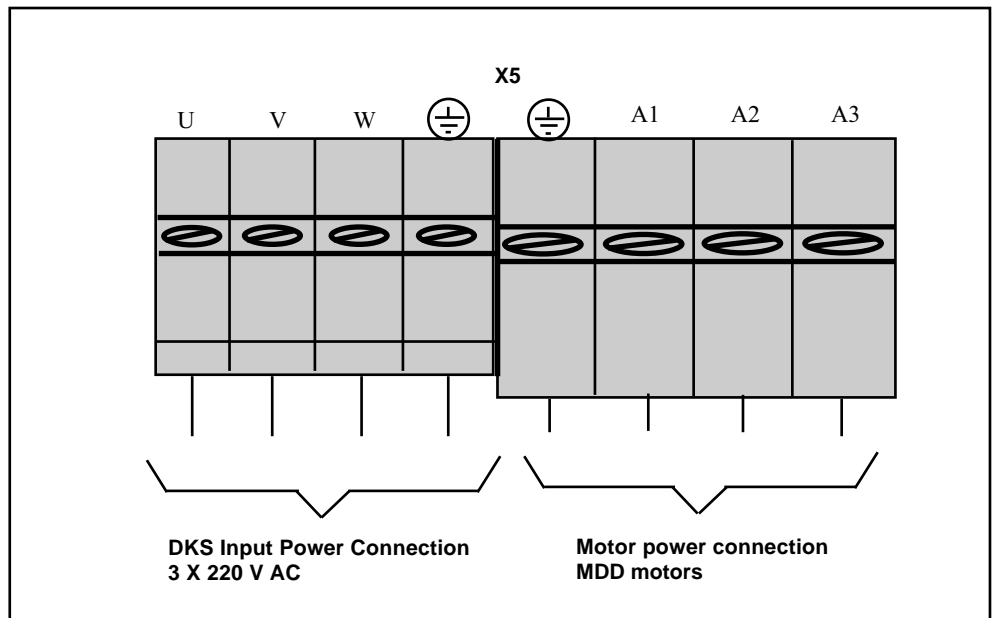

Figure 7.7: DKS power connection at terminal X5

It is preferable to use Indramat power cables for connecting the servo drives and MDD AC servo motors.

The INDRAMAT motor power cable contains:

- three wires for the motor power connection,
- one wire for the ground connection,
- a separate, shielded wire pair for monitoring motor temperature (PTC resistance in the motor), and,
- a separately shielded wire pair for the motor brake.

The motor power cable is available assembled from INDRAMAT.

Optionally, the cable can be made of four single-stranded wires (3 phases, 1 ground wire) with separately routed shielded leads for temperature resistance and brake connection.

Further information on technical specifications, connection and conducting cross sections can be found in the motor description and the cable catalog.

The maximum cable length is 75 meters if INDRAMAT cables are used.

⑦ Terminal X6,  
Motor Temperature  
Monitoring,  
Motor Holding Brake

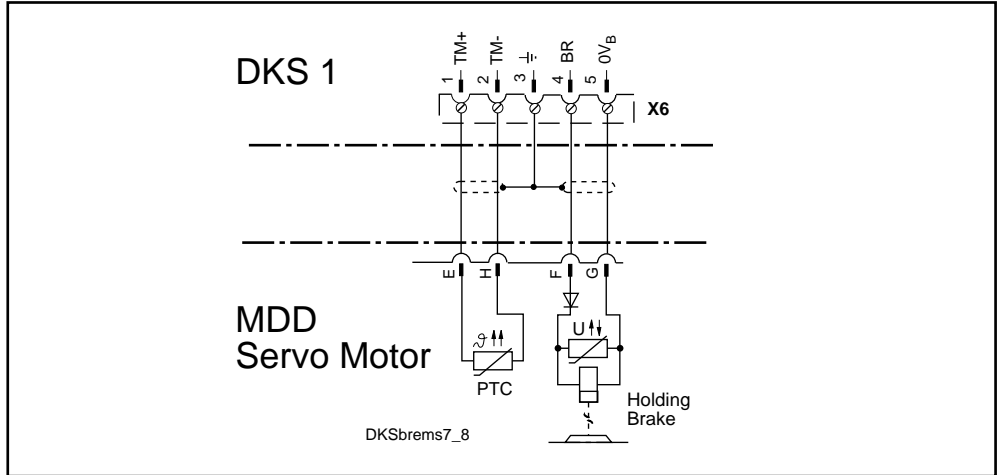

Figure 7.8: Connecting the motor holding brake and temperature monitoring circuit to terminal block X6.



**The brake on the MDD motors is not designed as a service brake. After approximately 20,000 motor revolutions, the brake disks will be completely worn down.**

Controlling the motor holding brake:

The releasing and engaging of the motor holding brake is monitored and controlled by the DKS servo drive. Additional information may be found in the Applications Manual.

⑧ Connector X4,  
Motor Feedback

The motor feedback is connected to terminal X4, as per the terminal connection diagram.

MDD servo motors equipped with a digital servo feedback (DSF) are to be operated with DKS drives 1.1- .....-D (see Figure 7.9).

MDD servo motors having a resolver feedback (RSF) are to be operated with DKS drives 1.1-.....-R (see Figure 7.10).



**Only those motor/servo drive combinations documented in the configuration sheets may be operated together.**

It is preferable to use INDRAMAT feedback cables for making the connection between the servo drive and the MDD servo motor feedback.

*Maximum  
Cable Length*

When using INDRAMAT feedback cables, the maximum cable length is 75 meters.

Additional information on INDRAMAT feedback cable may be found in the motor documentation.

## 7. Servo Drive Electrical Connections

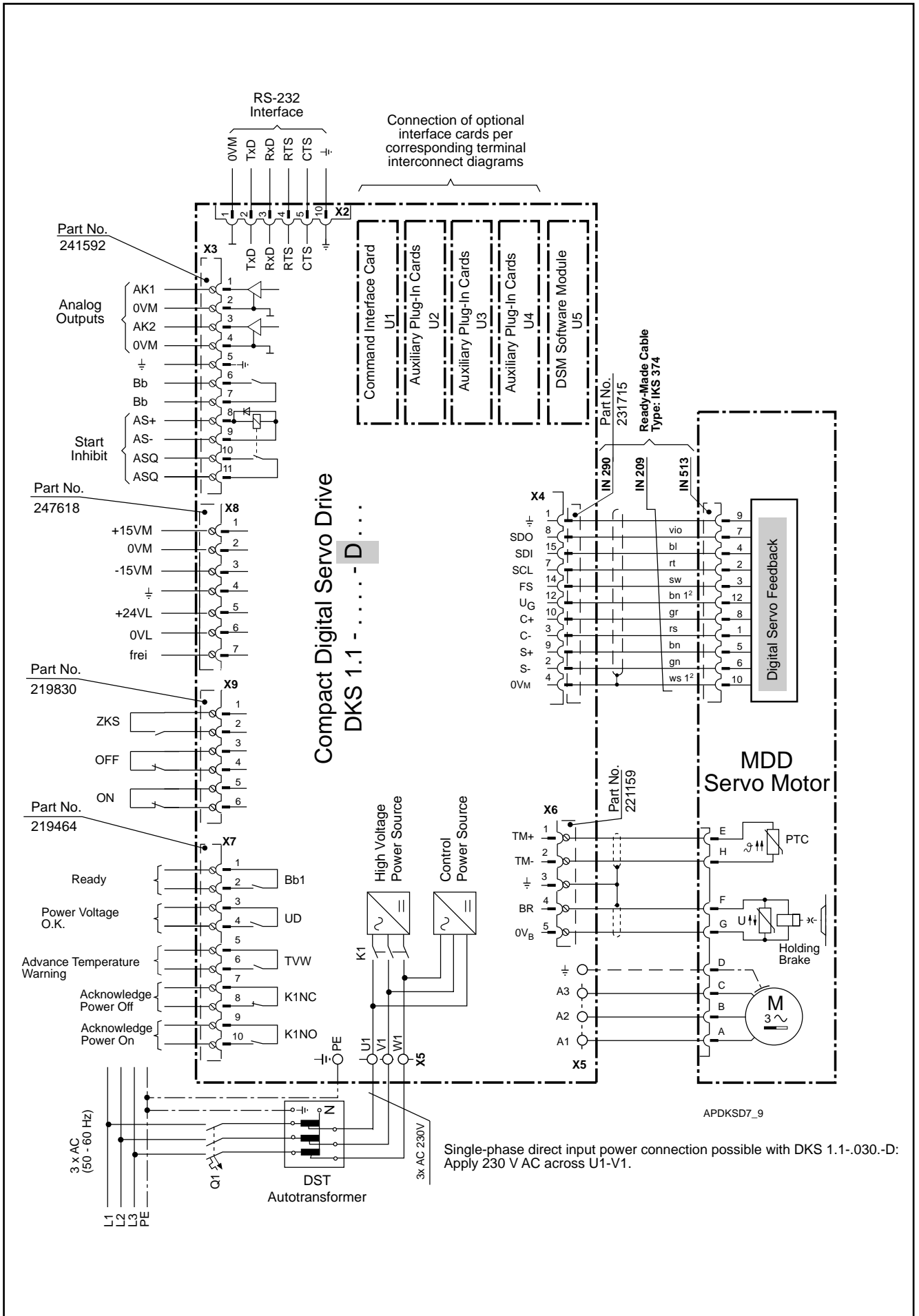

Figure 7.9: Terminal connection diagram for DKS 1.1-W...-D... basic unit  
(for motor with DSF digital servo feedback)

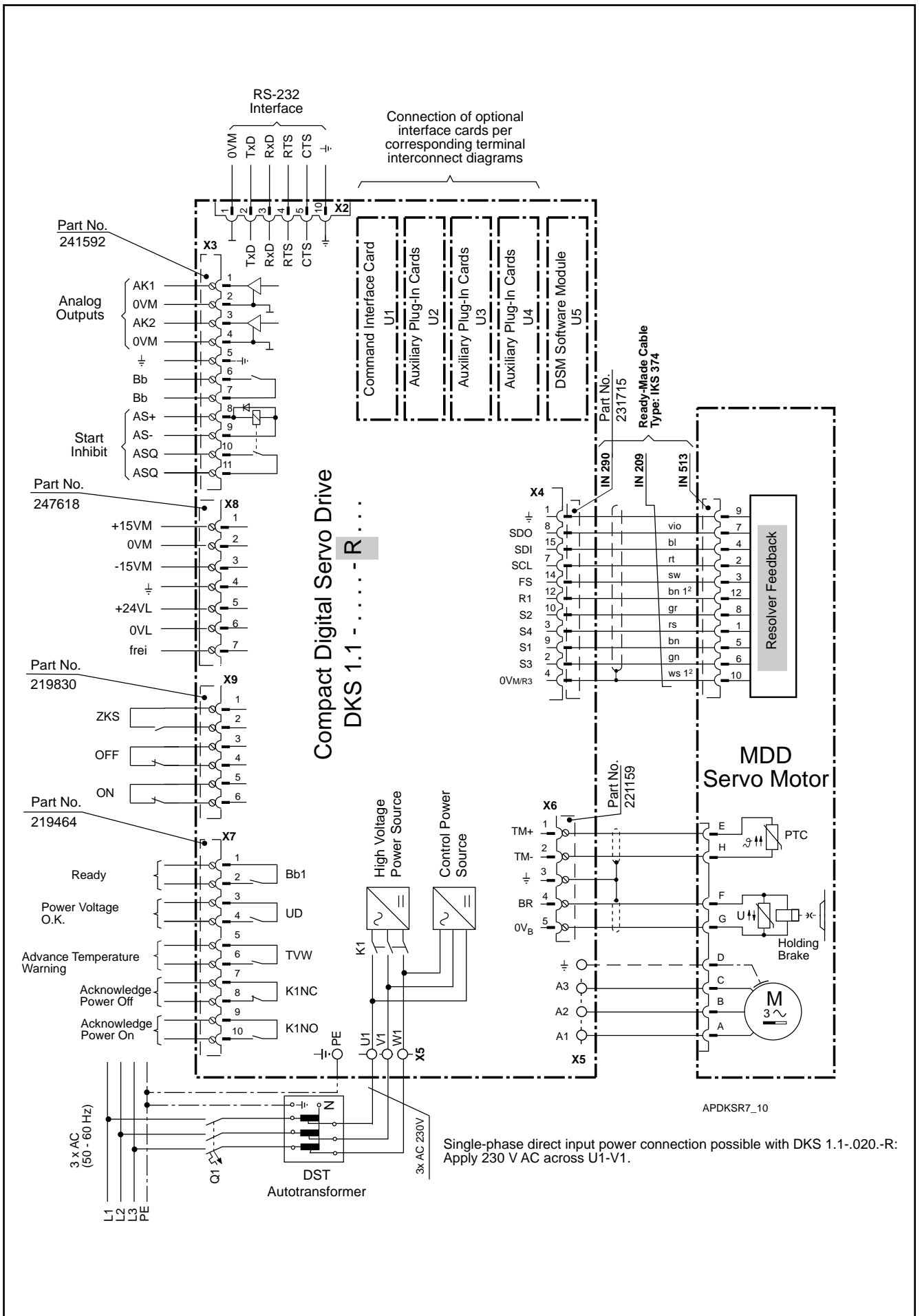

Figure 7.10: Terminal connection plan for DKS 1.1-...-R... basic unit (for motor with RSF resolver servo feedback)



### 7.3. Grounding Requirements for the Electrical Power System

The DKS can be connected without an isolation transformer to grounded 3-phase power systems.

With ungrounded 3-phase power systems, the phase voltage is present when there is a short (earth-conn) between the housing and the power connection of the DKS. If relatively high voltage differences between the phases and ground are expected for several seconds, then an isolation transformer will be needed to limit these overvoltages.

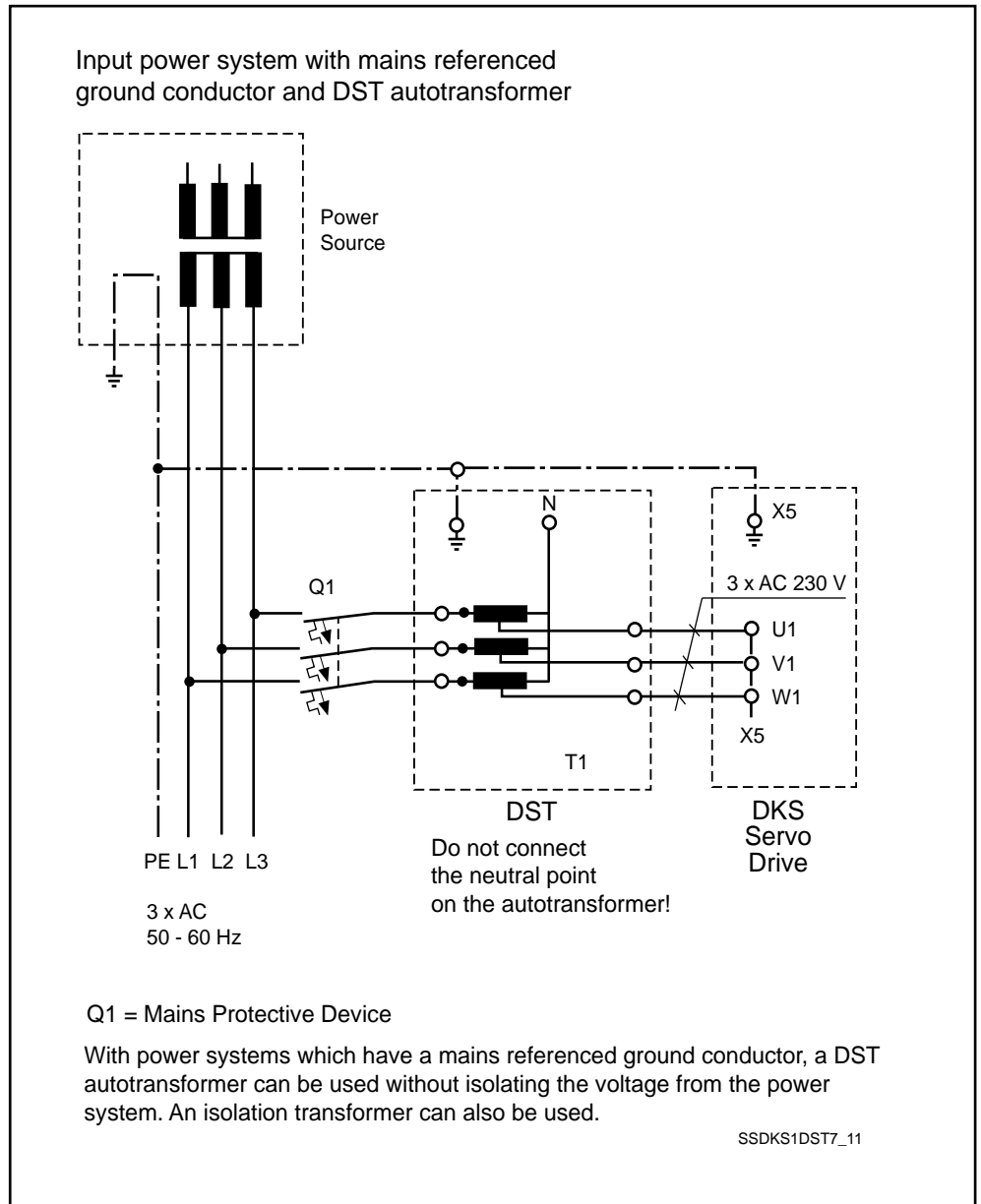

Figure 7.11: Power system with mains referenced ground conductor and DST 3-phase autotransformer.

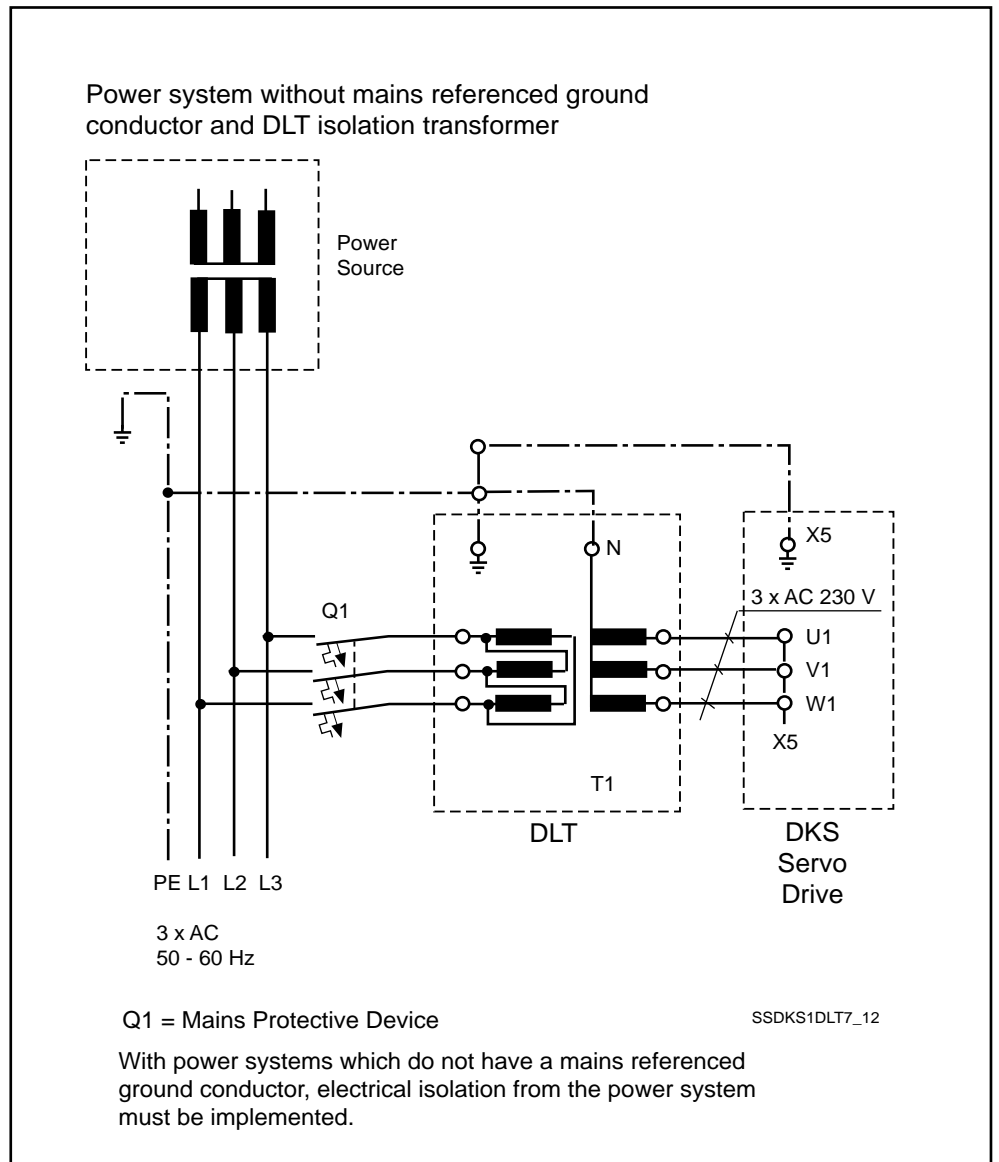

Figure 7.12: Input power system without mains referenced ground conductor and DLT 3-phase autotransformer.

### 7.4. Connection to the Electrical Power

As a general rule the DKS servo drive must be connected to 3-phase power. The servo drive DKS 1.1-.030.-... is an exception. The DKS 1.1-.030.-... can also be connected to single-phase power but the performance characteristics of the device are derated.

*Connection to 3-Phase Power*

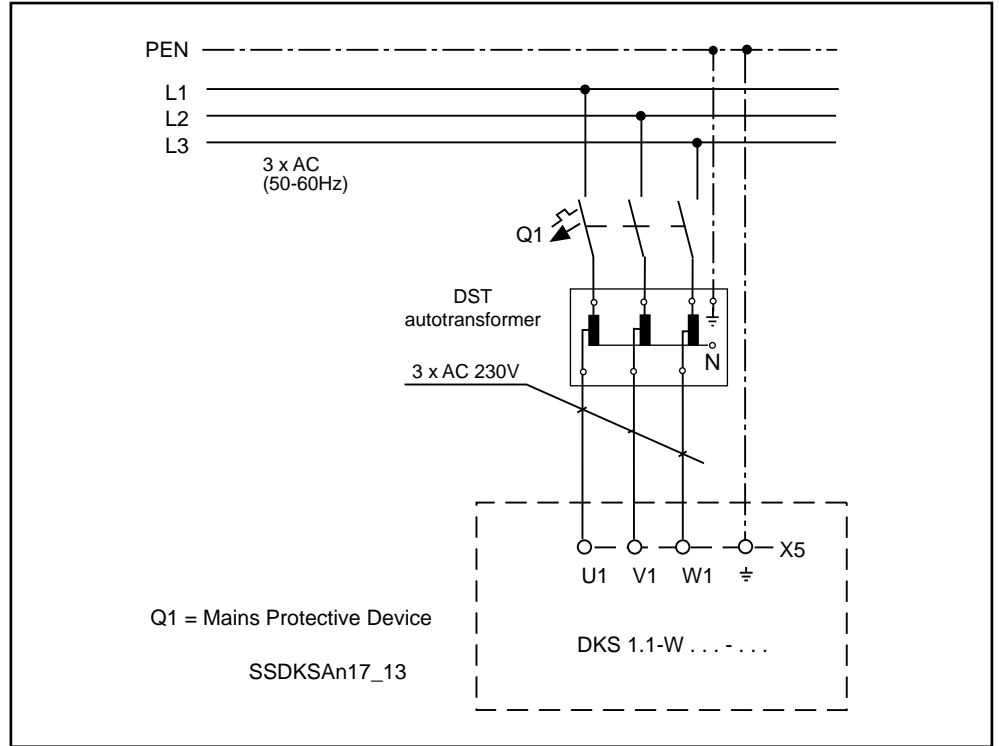

Figure 7.13: Connection to 3-phase input power .

*Connection to Single-Phase Power*

Connection to 1-phase input power is also possible with servo drives DKS 1.1-.030.-....

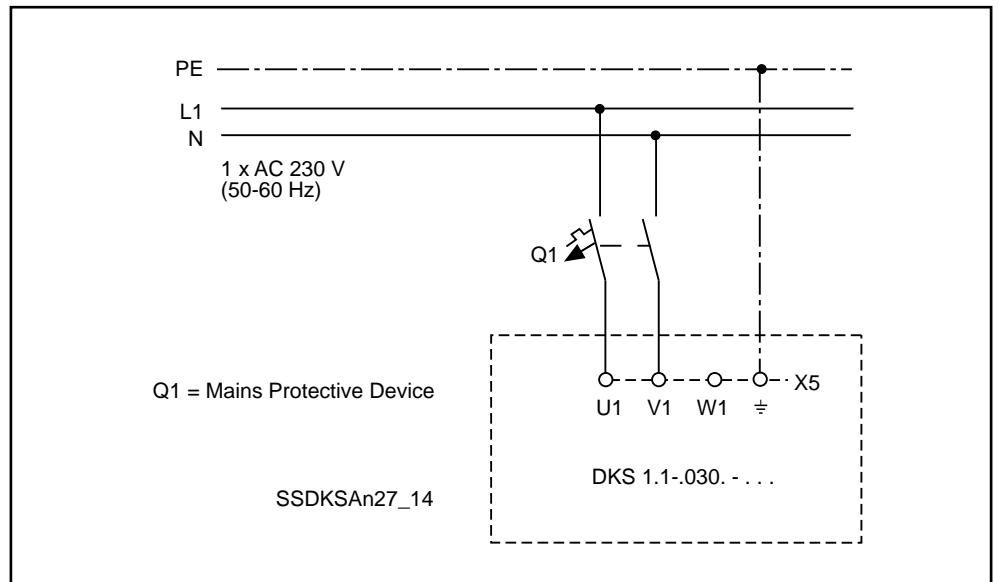

Figure 7.14: Connection to 1-phase power only possible with DKS 1.1-W030.-... servo drive.

**7.4.1. Direct Connection to Power System**

The DKS can be connected directly to 3-phase power systems having 3 x 230 V AC ( 10%), 50 - 60 Hz. The only requirement is to provide fuses/breakers for the power feed line.



**The DKS 1.1 -.030B-... servo drive can also be connected to a 230 V (50 - 60 Hz) single-phase system.**

*Power Source Protection*

The connection to the power system for the power section of the DKS can be protected with circuit breakers or fuses.

*With Fuses*

If fuses are used, then the protection system can be selected based upon the current at maximum drive load. If the servo drive is not 100% loaded, the fuses can be selected based upon the actual current in the input power line but must not be less than 10 A.

	DKS 1.1-W030B-...	DKS 1.1-W050A-...	DKS 1.1-W100A-...
3-Phase Connection	12 A	25 A	28 A
1-Phase Connection	16 A		

Figure 7.15: Current at maximum drive load

*With Circuit Breakers*

When circuit breakers are used, they may be designed based on the current at maximum drive load. If the circuit breakers are designed based upon the actual current in the DKS supply line, then it will be necessary to select circuit breakers 1.5 times the actual current.

*Current-Operated Ground Fault Circuit Breaker*

A current-operated ground-fault circuit breaker must not be installed in the DKS mains line (permitted per VDE 0160).

### 7.4.2. Connection to Electrical Power Via Transformer

If the line voltage is greater or less than 3 x 230 V AC, transformers having an output voltage of 220 V can be used.

If transformers are used, the required transformer specifications may be found in the selection data on „DKS with MDD,“ doc. no. 209-0069-4358.

**Overload Protection** The transformer can be protected against overload by using circuit breakers or fuses.

**With Fuses** If fuses are employed, use service class gL time delay fuses.

The rated current of the fuses should not be less than 3 times the transformer primary current.

**With Circuit Breakers** Current breakers may be selected according to the following table.

Determining Circuit Breakers for 3 x 380 V AC on the Primary Side of the Power Transformer.				
Power Rating in kVA	Primary Rated Current in A (at 3 x 380 V)	Recommended Circuit Breaker Siemens: Series 3 VE	Trip Range in A	Trip Point in A
0.5	3.0	3VE3000-2LA00	6.3...10	6.3(2.1xIN)
1.0	3.0	3VE3000-2LA00	6.3...10	6.3(2.1xIN)
1.5	3.0	3VE3000-2LA00	6.3...10	6.3(2.1xIN)
2.0	3.0	3VE3000-2LA00	6.3...10	6.3(2.1xIN)
2.5	3.8	3VE3000-2LA00	6.3...10	6,3(1.7xIN)
3.5	5.3	3VE3000-2MA00	10...16	10(1.9xIN)
4.0	6.1	3VE3000-2MA00	10...16	10(1.6xIN)
5.0	7.6	3VE3000-8MA00	12.5...20	12.5(1.6xIN)
7.5	11.4	3VE3000-2NA00	16...25	17.1
10.0	15,2	3VE3000-2NA00	16...25	23
12.5	19.0	3VE3000-2PA00	22...32	29

Figure 7.16: Selection of a circuit breaker based on the transformer rating.

**Current-Operated Ground Fault Circuit Breaker** A current-operated ground fault circuit breaker must not be installed in the DKS mains line (permitted per VDE 0160, section 6.5)

**DST 3-Phase  
Autotransformer**

**Nameplate:**

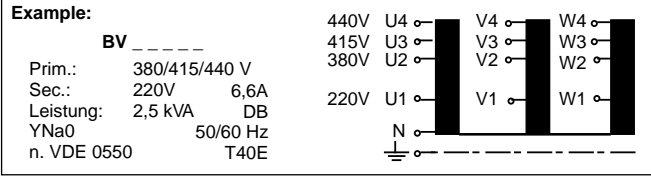

**Thermal Contact:**

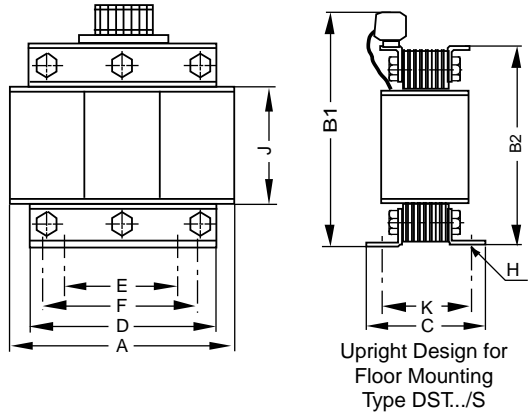
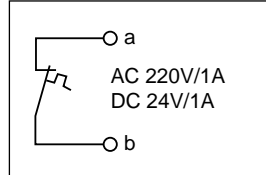

**Core Selection Diagram for 220V, 50/60Hz Output Voltage**

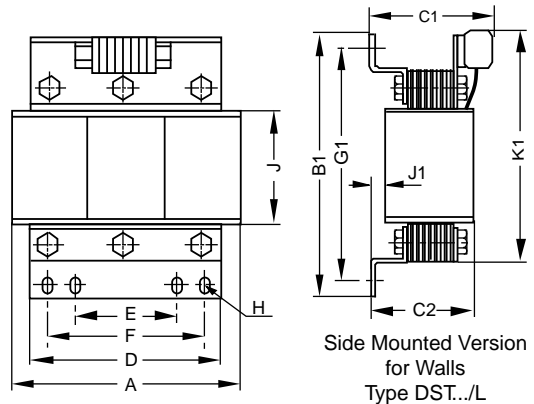
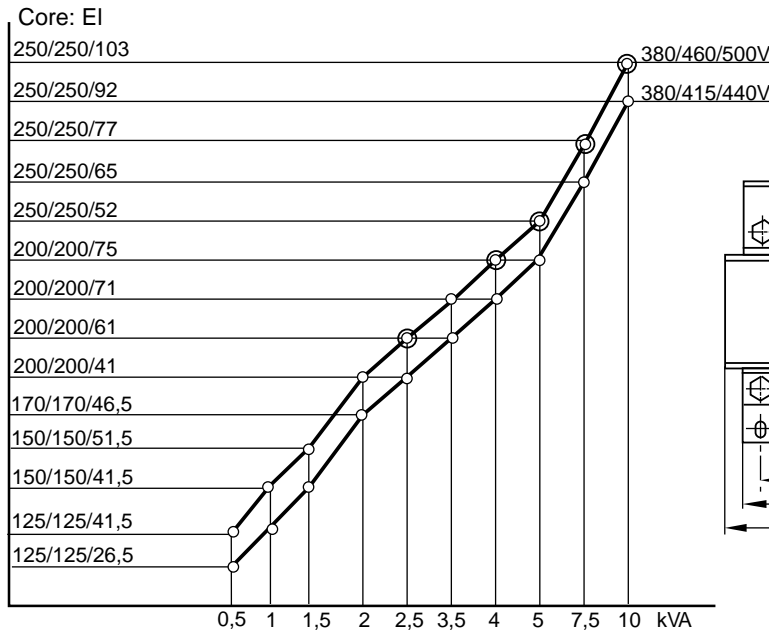

**Technical Data DST Transformers**

Core	Dimensions in mm															Wt. (kg)	
	A	B	B1	B2	C	C1	C2	D	E	F	G	H	J	J1	K		K1
170/170/46,5	205	235	210	180	120	110	101	170	95	145	205	7	102	13	85	205	12
200/200/41	240	270	260	210	120	135	102	200	110	170	245	11	120	17	90	235	18
200/200/61	240	270	260	210	140	155	117	200	110	170	245	11	120	17	110	235	22
200/200/71	240	270	260	210	150	170	132	200	110	170	245	11	120	17	120	235	25
200/200/75	240	270	260	210	155	174	136	200	110	170	245	11	120	17	125	235	26
250/250/52	300	350	325	265	140	162	127	250	140	210	305	11	150	20	110	290	31
250/250/65	300	350	325	265	155	175	140	250	140	210	305	11	150	20	125	290	36
250/250/77	300	350	325	265	165	187	152	250	140	210	305	11	150	20	135	290	42
250/250/92	300		325	265	180			250	140	210		11	150		150		48
250/250/103	300	350	325	265	195	214	177	250	140	210	305	11	150	20	165	290	53
125/125/26,5	150		165	130	75			125	70	100		6	75		55		4
125/125/41,5	150		165	130	90			125	70	100		6	75		70		5,5
150/150/41,5	180		190	160	105			150	80	125		7	90		75		8,5
150/150/51,5	180		190	160	115			150	80	125		7	90		85		10

MBDKSDST7\_17

Figure 7.17: 3-Phase DST autotransformers (dimensional drawings, selection of cores, nameplate).

3-Phase DLT  
Isolation Transformers

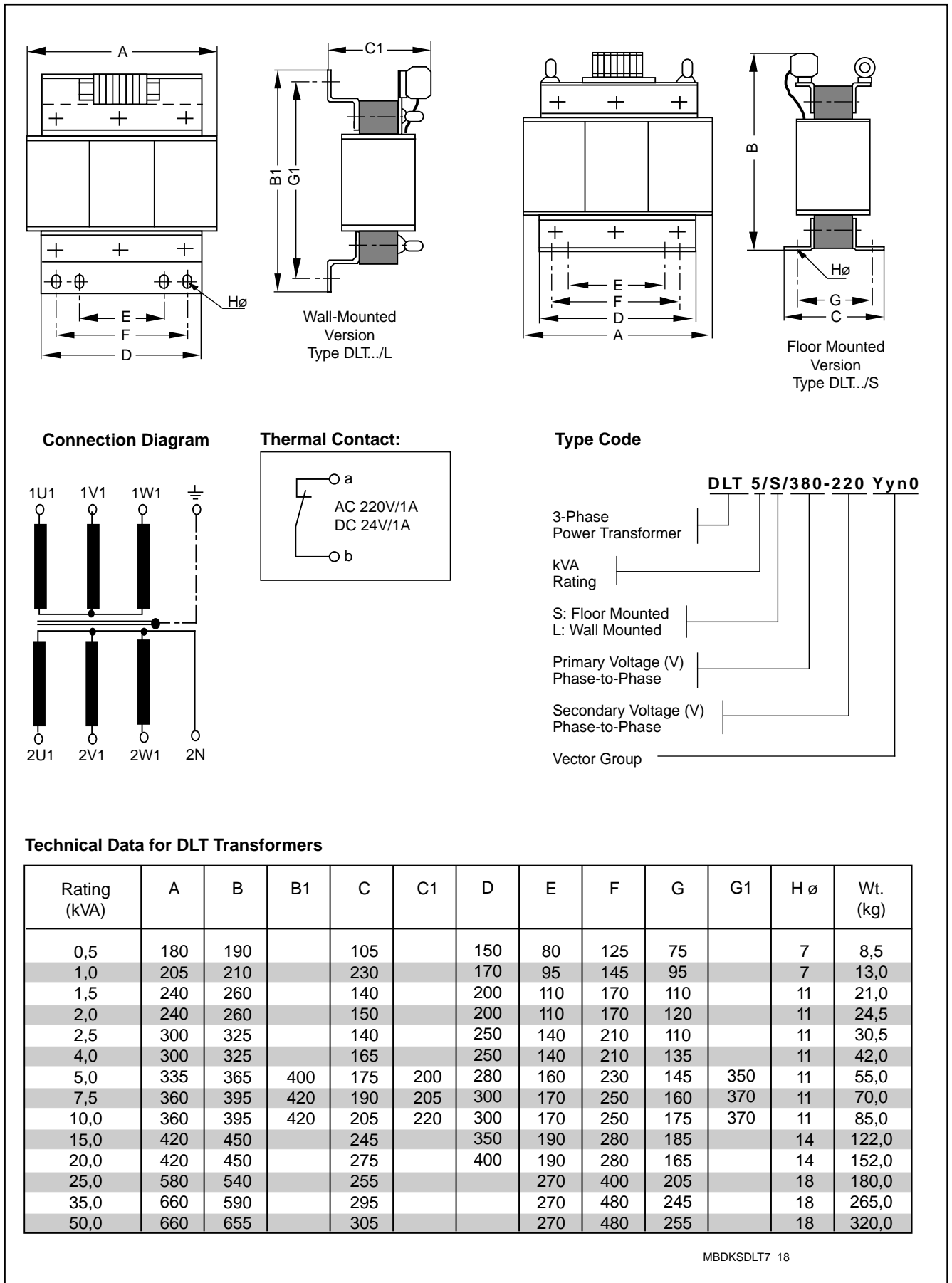

Figure 7.18: DLT three-phase isolation transformers (dimensions, connection diagram, nameplate).

## 7.5. Interface Circuit for the DKS Servo Drive

The general operating method as suggested by INDRAMAT is to control the main contactor and dynamic braking in the DKS. Selection of the control method and its effects will depend on the function offered and the responses of the entire system. It is, therefore, the responsibility of the machine builder.

*Stopping the Drive in the Event of Faults in the Drive's Electronic Circuitry With or Without Dynamic Braking*

The internal bus is shorted as a safety measure. This brakes drives in the event of trouble in the drive's electronic system.

When the bus is shorted, MDD servo motors are always braked to a stop, whether the electronic circuitry in the drive is still functioning or not.

Without dynamic braking, properly functioning drives can be braked at maximum torque. However, if there is trouble in the closed-loop electronic control system, or if there is a discontinuity in the feedback line, it should be expected that drives will coast without electrical braking. Dynamic braking can only be eliminated when nonbraked deceleration does not damage the system. As an alternative, motors equipped with mechanical holding brakes can be used.



**How to best stop the drive in the event of trouble will depend on the functions offered on the system. In the final analysis, this decision can only be reached by the system designer. Thus, the following recommendation is intended only as a guide to the system designer.**



*Controlling the DKS with Dynamic Braking* This means of controlling the DKS achieves high reliability at low expense. It makes the most effective use of the monitoring functions.

*Application* Normally this control method should be selected.

*Characteristics* Dynamic braking always stops MDD motors with braking whether the electronic circuitry on the drive is still functioning properly or not. Dynamic braking is only triggered in the event of drive faults.

*Operating Principle* When the emergency stop button is pressed, the main contactor in the DKS immediately drops out. The drive is brought to a stop in accordance with the programmed error reaction.

A drive error message from the DKS (Bb contact), an error message from the NC control (servo error), or the tripping of limit switches causes the main contactor to be turned off, and dynamic braking is triggered.

## 7. Servo Drive Electrical Connections

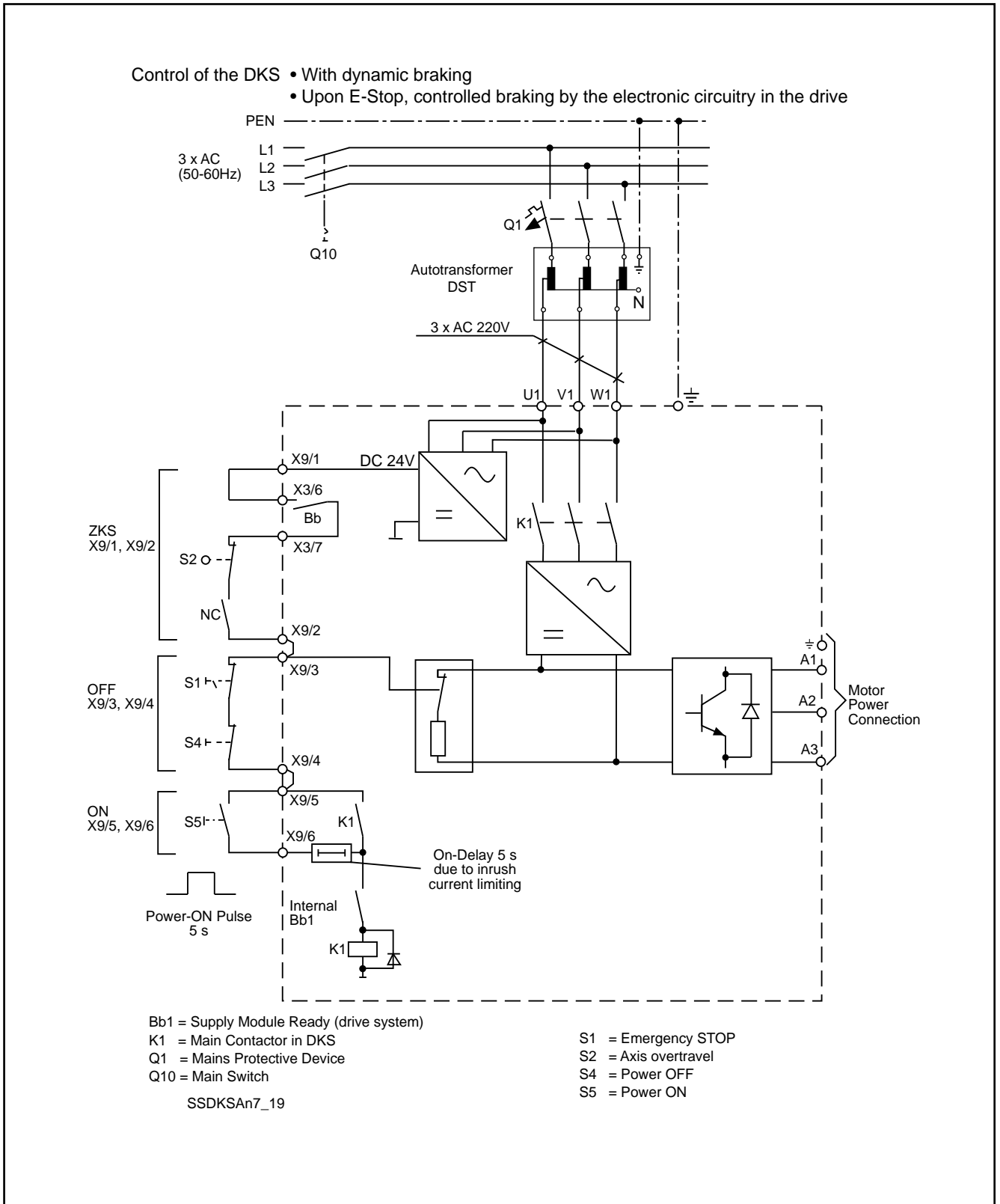

Figure 7.19: Control of the DKS for immediate power off in the event of an E-stop by means of dynamic braking.

## 8. Accessories

### 8.1. Connector Kits for DKS Basic Unit

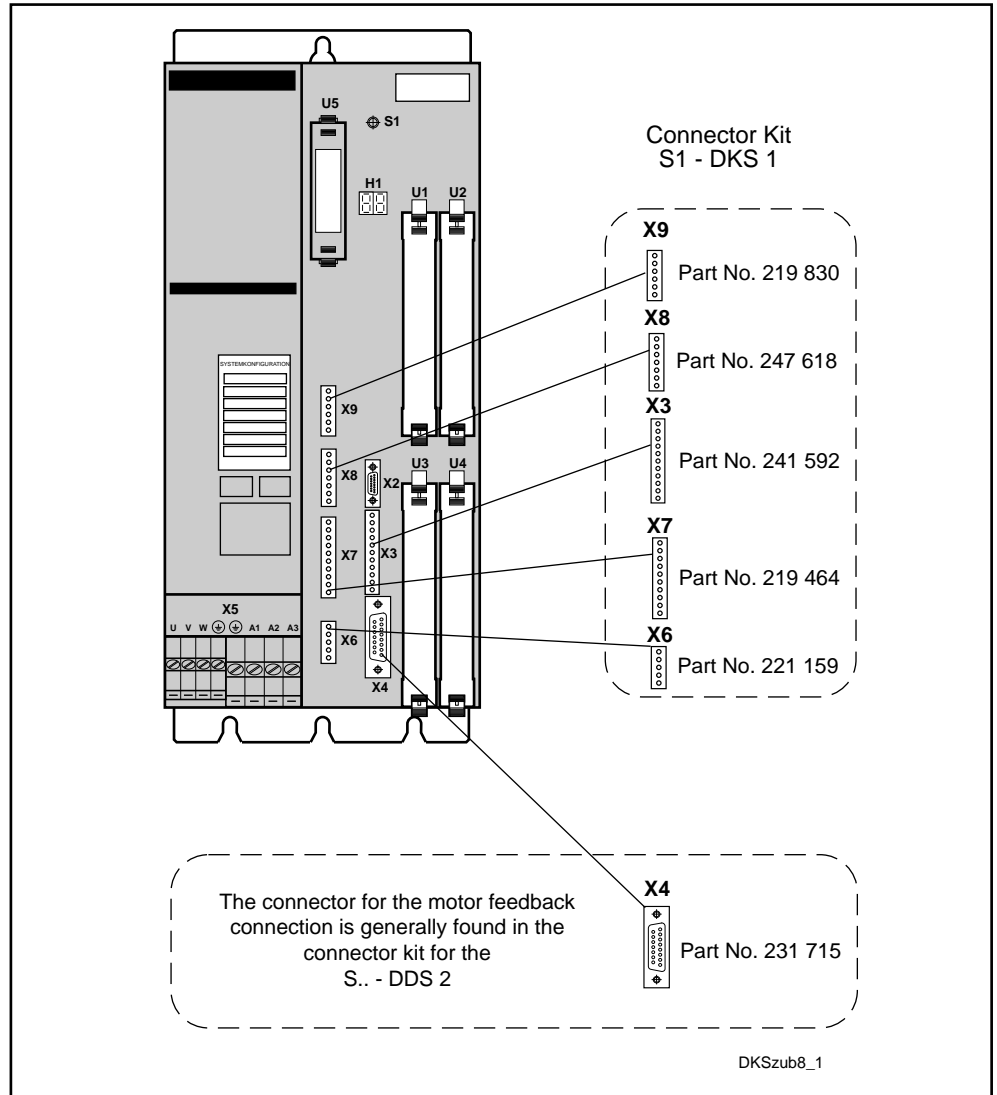

Figure 8.1: Connector Kit S1-DKS 1 for the DKS basic unit.

Connector kit S1-DKS 1 is generally needed for the DKS servo drive (basic unit).

Depending on the configuration, an S..-DDS 2 connector kit is also required. Connector kit S..-DDS 2 can be selected for the appropriate configuration as per Figure 8.2.

Additional optical fiber connections (cable and connectors or ready-made cables) are required for servo drives equipped with the SERCOS interface. These are not part of the accessories kits. Refer to Section 8.4 when selecting optical fiber connections.

An additional connector is required for the DLC 1.1 positioning card for servo drives equipped with positioning control, if interface RS-232 or RS-485 is used on the DLC positioning card.

## 8.2. Connector Kits for Configuration

A specific S..-DDS 2 connector kit is available for each configuration. Each connector kit includes the connector for the plug-in cards which are installed on the configured servo drive and the motor feedback connector (X4).

Configuration	Connector Kit	Notes
DA01-00	S 1-DDS 2	
DA02-00	S 1-DDS 2	
DA03-00	S 8-DDS 2	
DL01-00	S 9-DDS 2	2)
DL02-00	S10-DDS 2	2)
DL03-00	S11-DDS 2	2)
DL04-00	S12-DDS 2	2)
DL05-00	S13-DDS 2	2)
DS01-01	S 2-DDS 2	1)
DS03-01	S 3-DDS 2	1)
DS04-01	S 3-DDS 2	1)
DS05-00	S 7-DDS 2	1)
RA01-00	S 1-DDS 2	
RA02-00	S 1-DDS 2	
RL01-00	S 9-DDS 2	2)
RL02-00	S10-DDS 2	2)
RL03-00	S11-DDS 2	2)
RL04-00	S12-DDS 2	2)
RL05-00	S13-DDS 2	2)
RS01-01	S 2-DDS 2	1)
RS03-01	S 3-DDS 2	1)
RS04-01	S 3-DDS 2	1)

1) When using servo drives equipped with SERCOS interface, the optical fiber connections (cable and connectors or ready-made cables) must also be ordered (see Section 8.4).

2) When servo drives equipped with single-axis positioning control are used, the connector for the DLC positioning card are not included in connector kit S..-DDS 2. They must be ordered separately (see Section 8.3.).

Figure 8.2: Determining which connector kit is required for the configuration.

The following table lists the contents of the various connector kits.

Connector Kit	QTY	Part Number	Accessories
S 1-DDS 2	1	231 715	15-pin D-subminiature, male
	1	231 714	15-pin D-subminiature, female
	1	241 647	10-pin push-in terminal
S 2-DDS 2	1	231 715	15-pin D-subminiature, male
	1	241 591	9-pin push-in terminal
S 3-DDS 2	2	231 715	15-pin D-subminiature, male
	1	241 591	9-pin push-in terminal
S 7-DDS 2	3	231 715	15-pin D-subminiature, male
	1	241 591	9-pin push-in terminal
S 8-DDS 2	1	231 715	15-pin D-subminiature, male
	1	231 714	15-pin D-subminiature, female
	1	241 647	10-pin push-in terminal
	1	231 718	37-pin D-subminiature, female
S 9-DDS 2	1	231 715	15-pin D-subminiature, male
	1	231 718	37-pin D-subminiature, female
S10-DDS 2	1	231 715	15-pin D-subminiature, male
	2	231 718	37-pin D-subminiature, female
S11-DDS 2	1	231 715	15-pin D-subminiature, male
	3	231 718	37-pin D-subminiature, female
S12-DDS 2	2	231 715	15-pin D-subminiature, male
	1	231 718	37-pin D-subminiature, female
S13-DDS 2	2	231 715	15-pin D-subminiature, male
	2	231 718	37-pin D-subminiature, female

Figure 8.3: Parts lists for connector kits S..-DDS 2.

### 8.3. Connectors for Individual Components

You can use the following table to determine the proper connectors to be used with the components in the configured servo drive.

If you are ordering connector kits and ready-made cables, some of the individual connectors in the connector kit may not be necessary.

You can avoid this as follows:

When using ready-made cables do not order any S..-DDS 2 connector kits. Use the following table to select any connectors you may need in addition to the ready-made cables.

## 8. Accessories

Component	Terminal Block	Name of Connector	Part Number	Label Text	Comment
DDS 2, DDS 3 Servo Drive	X4	Connector for feedback connection, 15-D subminiature, male	231 715	STECKER IN290	Connector not needed when using ready-made feedback cable.
DKS 1 Servo Drive	X4	Connector for feedback connection, 15-D subminiature, male	231 715	STECKER IN290	Connector not needed when using ready-made feedback cable.
DSS 1.1, DSS 1.3 SERCOS Interface	X10	Connector for optical fiber cable	244 069 or 244 062	STECKER IN420 or STECKER IN425	IN 420 for optical fiber cable IN 414 with dia. 2.2 mm for connections inside the enclosure.
	X11	Connector for optical fiber cable	244 069  244 062	STECKER IN420 or STECKER IN425	
	X12	9-pin male connector	241 591	STECK-KL3,81 F MC 1.5/ 9ST B 1-9	
DAE 1.1 Analog interface incremental encoder Emulator	X13	10-pin male connector	241 647	STECK-KL3,81 F MC 1.5/10ST B 1-10	
	X14	15-pin D-subminiature, female contacts	231 714	STECKER IN289	
DAA 1.1 Analog interface with absolute encoder emulator	X15	10-pin male connector	241 647	STECK-KL3,81 F MC 1.5/10ST B 1-10	
	X16	15-pin D-subminiature, female contacts	231 714	STECKER IN289	
DZF 1.1 Gear encoder interface	X20	15-pin D-subminiature, male contacts	231 715	STECKER IN290	
DLF 1.1 High-resolution position interface (sine-wave signals)	X23	15-pin D-subminiature, male contacts	231 715	STECKER IN290	
DEF 1.1 Incremental position interface (square-wave signals)	X22	15-pin D-subminiature, male contacts	231 715	STECKER IN290	
DEF 2.1 Incremental position interface (square-wave signals)	X24	15-pin D-subminiature, male contacts	231 715	STECKER IN290	
DEA 4.1 Input/Output (I/O) Card	X17	37 pin D-subminiature, female contacts	231 718	STECKER IN293	
DEA 5.1 Input/Output (I/O) Card	X32	37 pin D-subminiature, female contacts	231 718	STECKER IN293	
DEA 6.1 Input/Output (I/O) Card	X33	37 pin D-subminiature, female contacts	231 718	STECKER IN293	
DLC 1.1 Positioning Card	X30	Ready-Made Cable			Ready-made cable IKS 745/... for programming and display unit (max. length 30 m)
	X31	9-pin D-subminiature, male contacts	231713	STECKER IN288	

*Fig 8.4: Selection of individual connector for components for the configured servo drive.*

### 8.4. Selection of Optical Fiber Connections

Communication between the drive and the control takes place over optical fiber cable with the SERCOS interface.

Additional information on the subject of „fiber optics“ may be found in the Applications Description for Fiber Optics Handling (doc. no.: 209-0090-4101-xx).

In this description of „fiber optics handling“, the following items are discussed:

- fiber optics in general
- basic principles for planning fiber optics transmission systems
- routing specifications for optical fiber cable
- measuring attenuation in ready-made optical fiber cables
- available optical fiber FSMA connector and optical fiber cable
- assembly instructions for FSMA connectors
- tools for assembling optical fiber cables

Use the following drawing to determine the information needed to order optical fiber cables for the entire system.

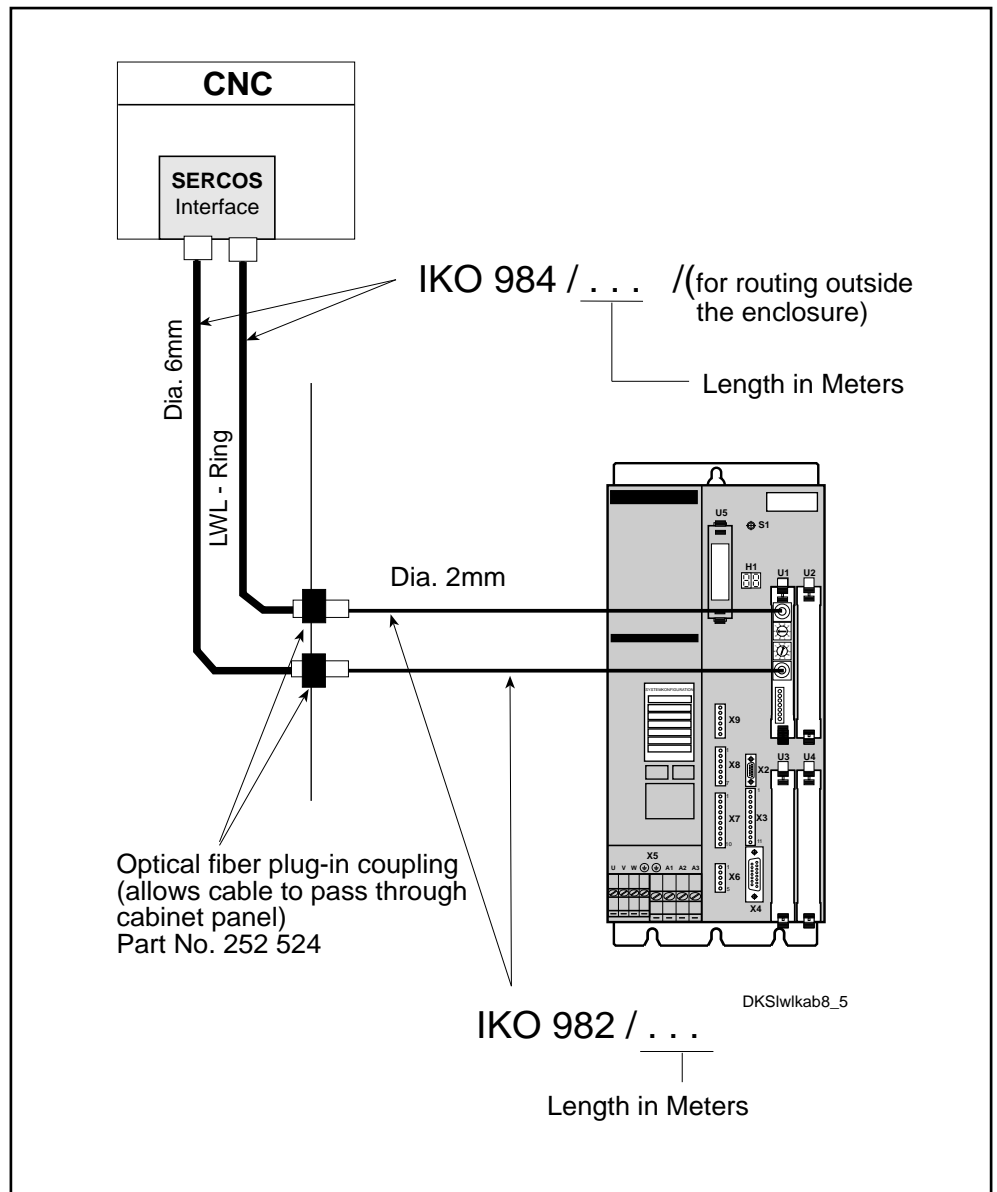

Figure 8.5: Selecting ready-made cables for the SERCOS ring.

## 9. Condition as Shipped

The products are shipped in cartons. In the case of individual or mixed orders (several different units) the equipment is packed in non-reusable packaging. Accessories are in a separate box. All the individual boxes are combined for shipment in a larger shipping container (box or pallet).

If several such devices are delivered, returnable packaging may be used.

An envelope containing two delivery slips is found in the shipping container. No additional shipping papers are present, unless specifically requested.

Damage-free unpacking is ensured by opening at the glued seams..



## 10. Product Identification

In the event of mixed orders the shipping container contains the individually packaged drives and their accessories. If the order contains multiple quantities of the same devices, the accessories may be contained in a separate shipping container.

The DKS packaging is marked by a bar-coded label. This label identifies the contents as to version and contains information relating to processing the order.

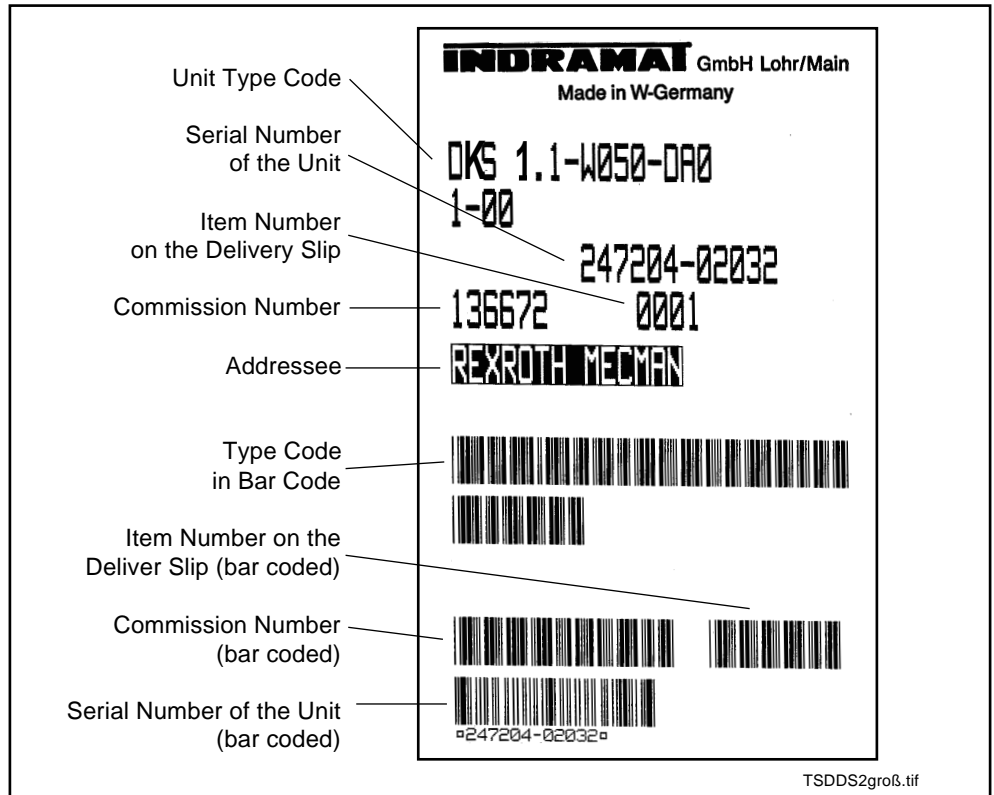

Fig. 10.1: Bar code label on DKS packaging (example)

If more than one of the same unit are contained in the packaging, the serial numbers of all the units it contains are located on the bar code label (only with reusable packaging).

There is a label on the side of the DKS giving all information needed for service. It corresponds to the bar code label and lists the shipping date.

The configuration label is on the DKS front panel. It is also visible when the DKS is installed in the drive package. (The label on the side is not!).

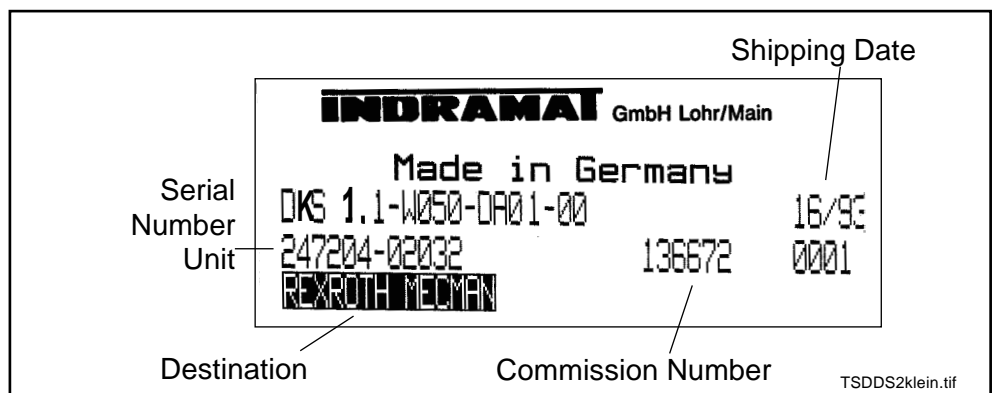

Fig. 10.2: Label for service mounted on the side of the unit (example).

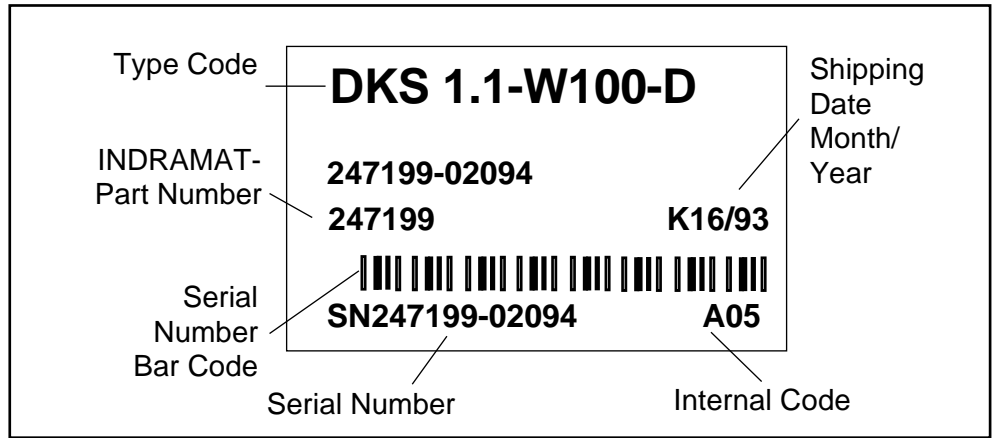

Fig. 10.3: Label on DKS 1 basic unit (example, on front panel)

**Accessories** The accessories are packed in bags marked with the ordering code. A packing slip is included with the accessories. It contains the order number and lists the parts included in the accessories kit. With ready-made cables, the order code appears on a label attached to the cable. Non-ready-made cables („raw cables“) have the cable number printed on them.

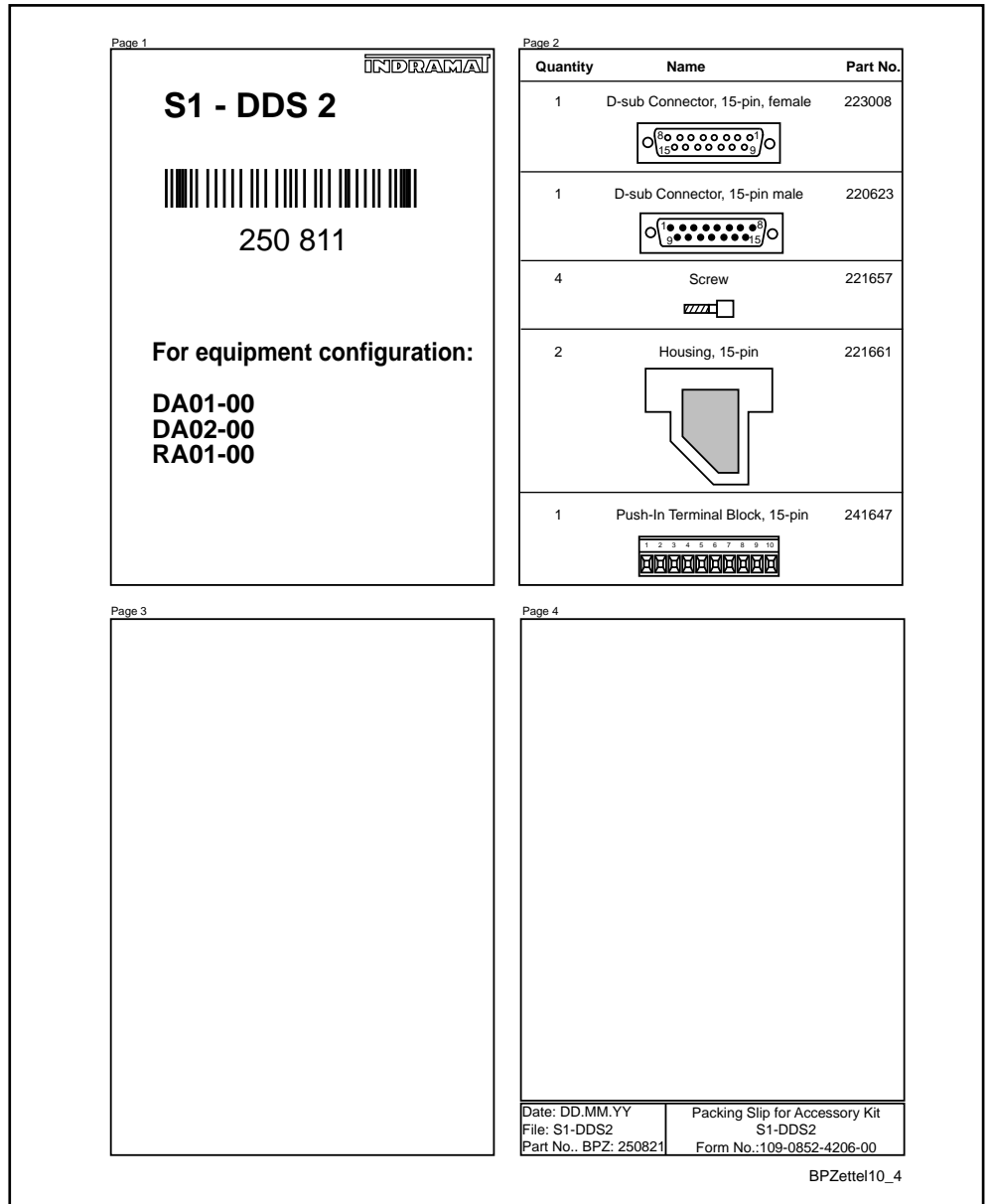

Fig. 10.4: Typical packing slip.

## 11. Storage and Transport

Store the servo drives in a dry, dust- and vibration-free environment.  
Permissible temperature range -30°C to +85°C.

Use a shock absorbing support if there is a potential for heavy shock and vibration to occur during transit!

Handling warnings on packaging:

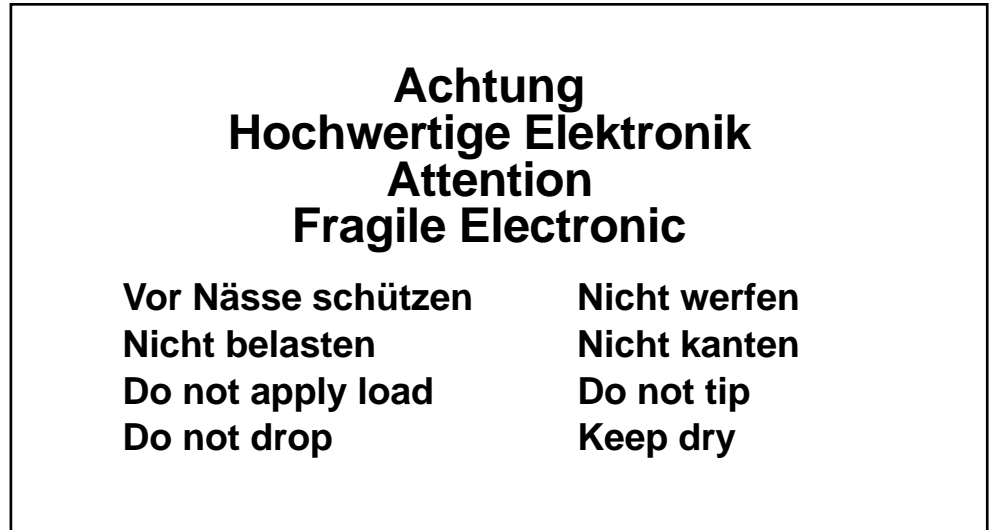

Fig. 11.1: Handling instructions for shipping.

## 12. Index

### A

Accessories 31, 41  
Analog Interface 8  
Auxiliary Plug-In Cards 9

### B

Basic Dimensions 19  
Basic Unit 7  
Brake 24  
Bus Connection 25

### C

Cable Length 23  
Command Interface Card 8  
Condensation 16  
Configuration 12  
Configuration Label 10  
Configured Servo Drive 7  
Connection 21  
Connectors 34  
Cooling Units 16

### D

Delivery Condition 39  
Diagnostics Outputs 26  
Dimensional Drawing 20

### E

E..-DDS 2 31,32  
Elevation 15

### G

Ground Connection 23

### H

High-Resolution Position Interface 9  
Humidity 15

### I

Identification of Product 40  
Incremental Position Interface 9  
Intermediate-Circuit Connection 25

### L

Loading Resistances 37  
Location of Servo Drives 18

### M

Motor Feedback 28  
Motor Power Cable 23  
Motor Temperature Monitor 24

**N**

Nameplate 11

**O**

Optical Fiber Cable 36

Optical Fiber Connections 36

**P**

Power Losses 14

Power Requirements 13

Power Source Devices 6

Protection Class 18

**R**

Ready State 37

Ready State Contact 27

RS-232 Interface 28

**S**

S..-DDS 2 31, 33

SERCOS Interface 8

Single-Axis Positioning Module 8

Software Module 9

Start Inhibit 27

Storage and Transport 42

System Overview 5

**W**

Water Condensate 16



# 13. Supplementary Documentation

## Intelligent Digital AC Servo Drives with Compact Servo Drives

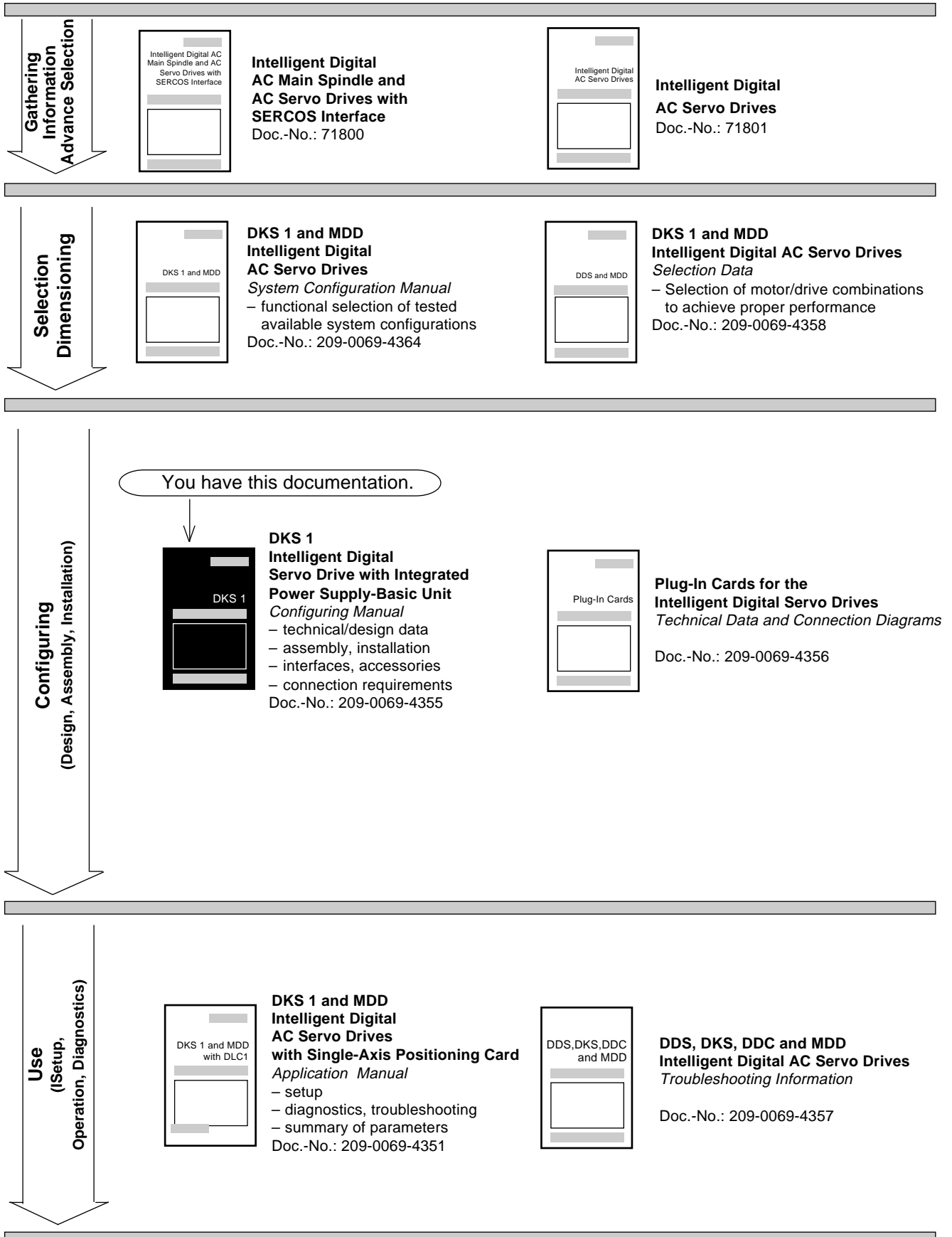
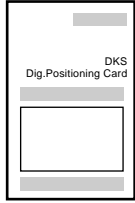

Fig. 13.1: Summary of additional documentation.



**DKS**  
**Digital Positioning Card**  
 Doc.-No.: 71901

Gathering  
 Information  
 Advance Selection

Selection  
 Dimensioning

**Digital AC Servo Motors**  
*Configuring*

- technical data
- design data
- available models/options
- accessories

MDD021 Doc.-No.: 9.578.060.4

025 Doc.-No.: 9.578.061.4

MDD065 Doc.-No.: 9.578.054.4

071 Doc.-No.: 9.578.063.4

090 Doc.-No.: 9.578.059.4

093 Doc.-No.: 9.578.058.4

095 Doc.-No.: 9.578.057.4

112 Doc.-No.: 9.578.064.4

115 Doc.-No.: 9.578.065.4

117 Doc.-No.: 9.578.065.4

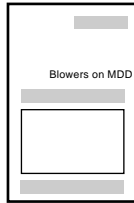

**Blowers or Mounting  
 on MDD Servo Motors**  
*Configuring*

- technical data
- design data
- assembly
- matching with MDD motors

Doc.-No.: 9.578.003.4

Configuring  
 (Design, Assembly, Installation)

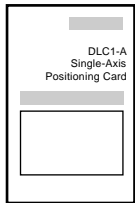

**DLC1-A**  
**Single-Axis Positioning Card**  
**for Digital Servo Drives**  
*Programming Manual*  
 Doc.-No.: 109-0852-4102

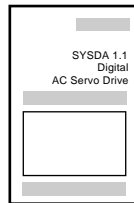

**SYSDA 1.1 Setup Aids for Intelligent  
 Digital AC Drives Equipped with  
 SERCOS Interface**  
*Application Manual*

- technical data
- components
- operation
- setup

Doc.-No.: 209-0069-4322

Use  
 (Setup,  
 Operation, Diagnostics)



